

NO.	DESCRIPTION	SPECIFICATION	Q'TY	MAKER	REMARK
01	SOL' VALVE	4F620-20-LS-AC110V	1	CKD	
02	SOL' VALVE	4F630-20-LS-AC110V	3	CKD	
03	SOL' VALVE	4F520-15-LS-AC110V	1	CKD	
04	SPEED CON	SC-20A	4	CKD	
05	SPEED CON	SC1-15	2	CKD	
06	SILENCEER	SLW-15A	2	CKD	
07	SILENCEER	SL-20A	8	CKD	
08	VALVE & ACTUATOR	ED75H-BA25G-DBD-SFM-G	1	KOVATEC	
09	FILTER	F4000-15-W-A15	1	CKD	
10	LUBRICATOR	L4000-15-W-A15W	1	CKD	
11	FILTER	F8000-20-W-A20W	4	CKD	
12	LUBRICATOR	L8000-20-W-A20W	4	CKD	

T/BOX : OUT OF SCOPE
 PIPING : OUT OF SCOPE

- SPECIFICATION —
- OPERATING AIR PRESSURE : 5 ~ 10bar
 - ELECTRIC SOURCE : ELEC. POWER - 440VAC / 60Hz
 : SOLENOID VALVE - AC 100V
 : SENSOR & INDICATOR - DC 24V

SGHITEC

NO.	DESCRIPTION	MAT'(KS)	UNIT	TOTAL QUANTITY	PERIANT	TOTAL WEIGHT(kg)	REMARK'S
posco							SCALE: 1/2
							PROJECTION:
							DIMENSION: mm
TITLE	K1H PLANT	ITEM NO. SW240408VS-1		FACILITY		EQUIPMENT	
SCHEMATIC DIAGRAM OF Pneumatic Valve Stand							MAKER
							DWG. NO. SC-0314-D-001
POSCO	DRAWN	CHECKED	REVIEWED	APPROVED	DATE	POSCO DWG. NO.	01P-XX00X000000000
					2024.03.14		

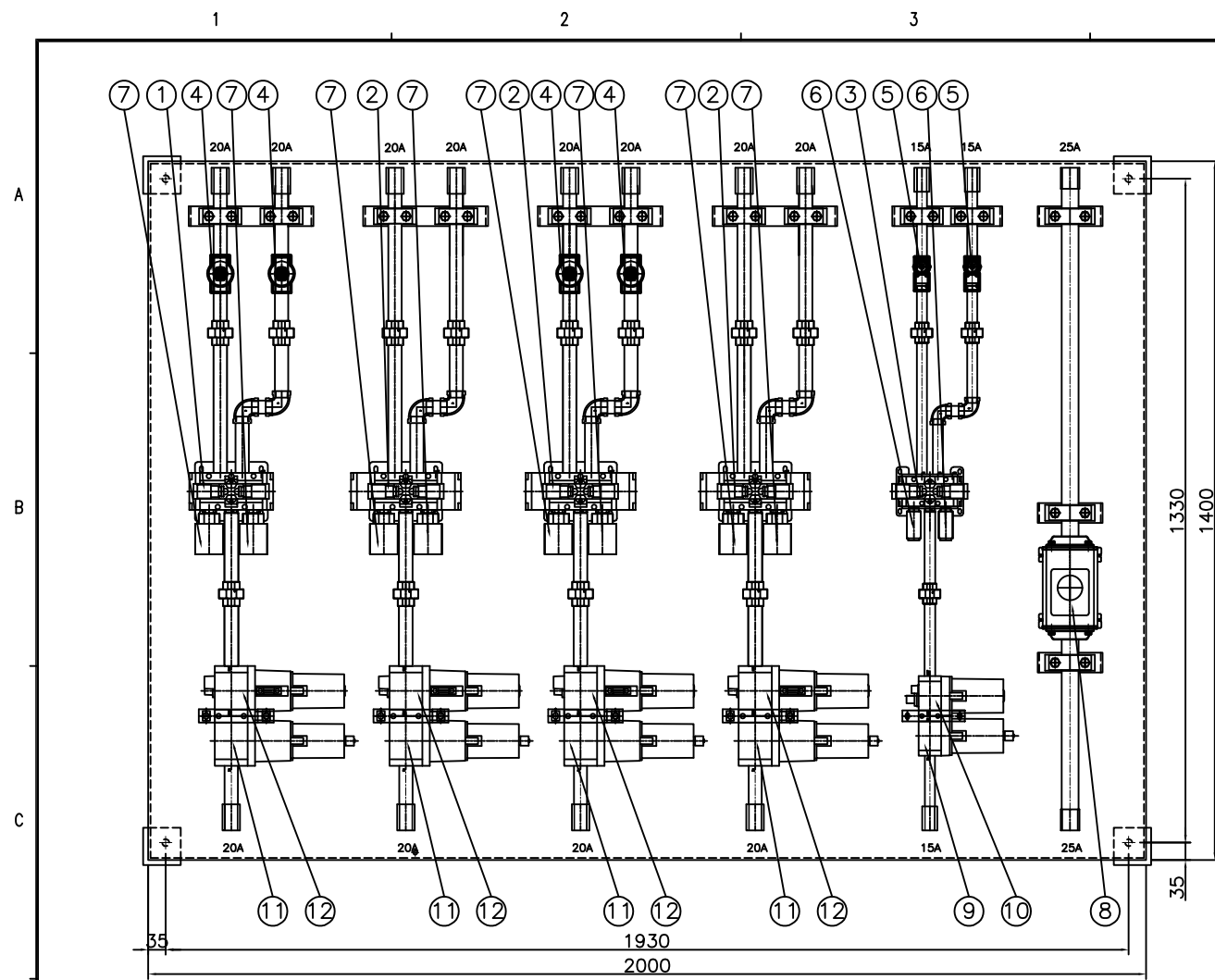

NO.	DESCRIPTION	SPECIFICATION	Q'TY	MAKER	REMARK
01	SOL' VALVE	4F620-20-LS-AC110V	1	CKD	
02	SOL' VALVE	4F630-20-LS-AC110V	3	CKD	
03	SOL' VALVE	4F520-15-LS-AC110V	1	CKD	
04	SPEED CON	SC-20A	4	CKD	
05	SPEED CON	SC1-15	2	CKD	
06	SILENCEER	SLW-15A	2	CKD	
07	SILENCEER	SL-20A	8	CKD	
08	VALVE & ACTUATOR	ED75H-BA25G-DBD-SFM-G	1	KOVATEC	
09	FILTER	F4000-15-W-A15	1	CKD	
10	LUBRICATOR	L4000-15-W-A15W	1	CKD	
11	FILTER	F8000-20-W-A20W	4	CKD	
12	LUBRICATOR	L8000-20-W-A20W	4	CKD	

FOR REFREANCE

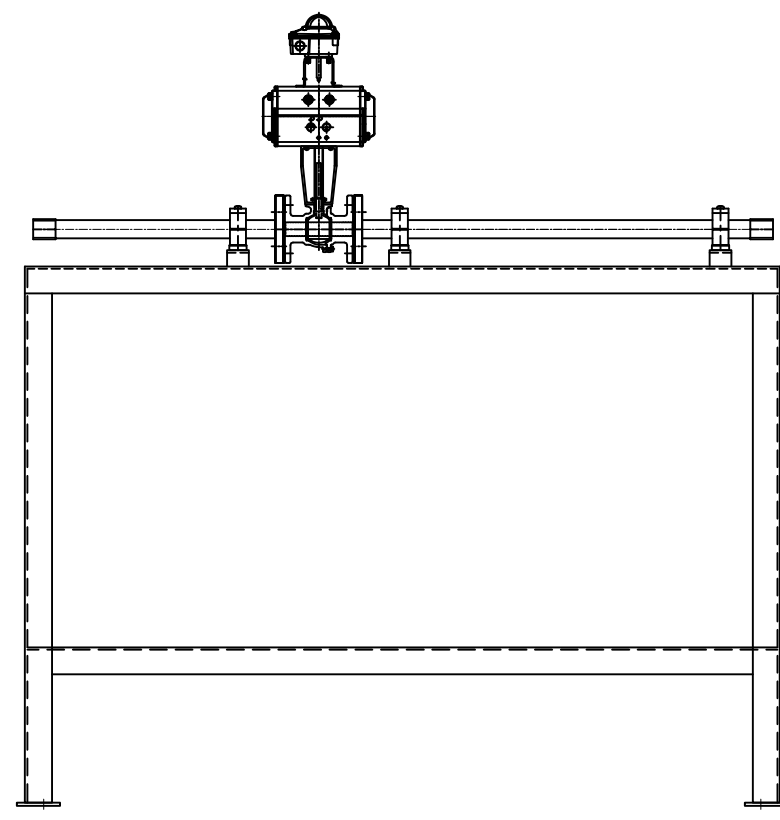
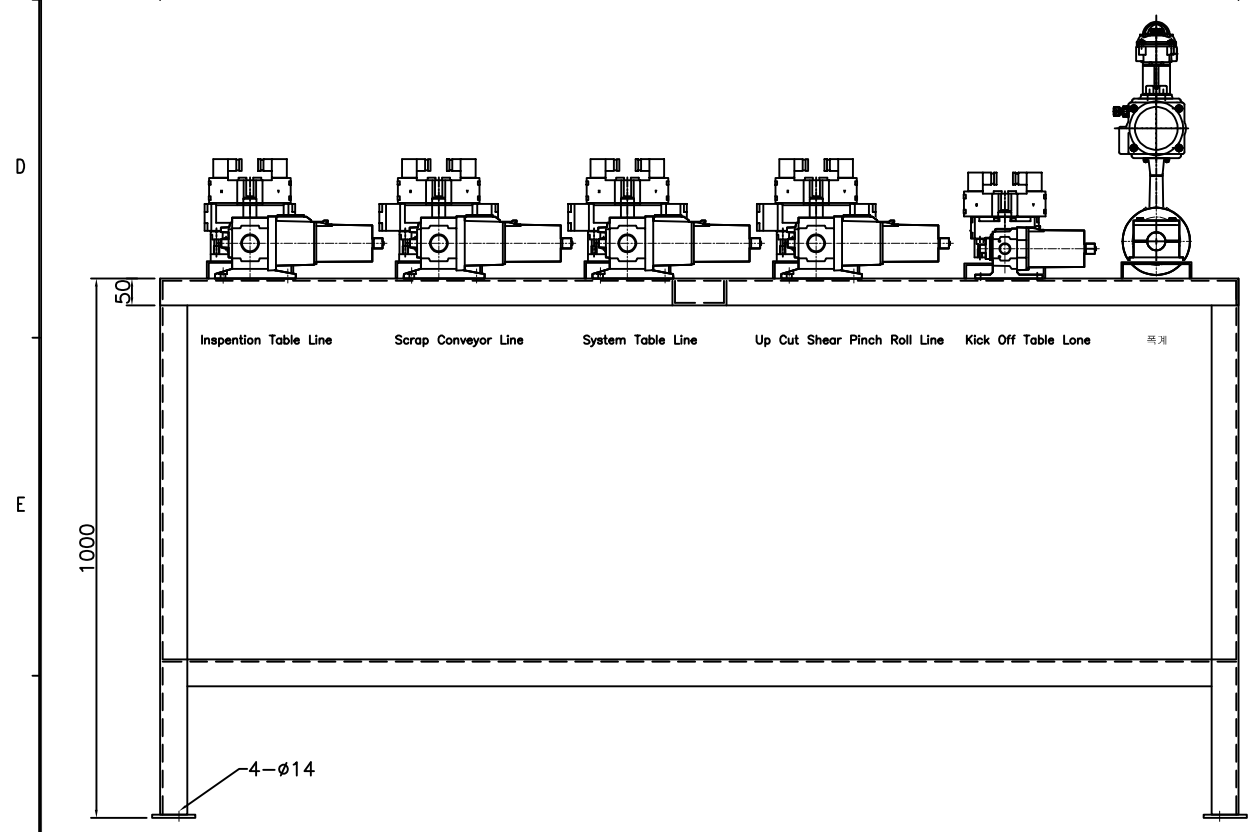

- SPECIFICATION -
 1. OPERATING AIR PRESSURE : 5 ~ 10bar
 2. ELECTRIC SOURCE : ELEC. POWER - 440VAC / 60Hz
 : SOLENOID VALVE - AC 100V
 : SENSOR & INDICATOR - DC 24V

SGHITEC

NO.	DESCRIPTION	MAT'(KS)	UNIT	TOTAL QUANTITY	PERUNIT WEIGHT(kg)	TOTAL WEIGHT(kg)	REMARK'S
posco							SCALE: 1/2
TITLE: K1H PLANT - SCHEMATIC DIAGRAM OF Pneumatic Valve Stand							PROJECTION: 1st Angle
ITEM NO. SW240408VS-1							SIZE: A1
FACILITY: SCHEMATIC DIAGRAM OF Pneumatic Valve Stand							DIMENSION: mm
POSCO	SIGNATURE	DATE	DRAWN	CHECKED	REVIEWED	APPROVED	POSCO DWG. NO. 01P-XX00X00000000
		2024.03.14					