

Explosion Proof Zero Speed Switches

The DAZIC® 2100 EP and 8100 EP Series Zero Speed Switches are available with NEMA 7/9 rated cast aluminum housings for use in indoor, hazardous locations.



Operating Speeds:

*2100 EP Series — 4 to 2000 RPM
8100 EP Series — 0.5 to 25 RPM*

2100 EP and 8100 EP Series	
Driver	Shaft-to-shaft
Shaft Diameter	1/2" (1.27 cm)
Driver Torque Required	.0208 ft-lb (.0282 Nm)
Temperature Tolerance	-40° F to +250° F -40° C to +121° C
Housing Options	Cast Aluminum
NEMA Rating	7 / 9
Mounting	Base mount
Dimensions L x W x H	7.29" x 6.55" x 5.93" (18.52 cm x 16.64 cm x 15.06 cm)
Wiring Contact Options	SPDT, DPDT, SPDT(2)
Weight	13 lbs. (5.9 kg)

* The Factory Mutual Approved Explosion Proof (NEMA 7/9) housing is constructed of high strength cast aluminum alloy and approved for Class I, Division 1, Groups C and D; as well as Dust-Ignition Proof for Class II, Division 1, Groups E, F, and G hazardous locations, indoors.

Stop an entire operation if one machine fails.

*Reduce downtime • Protect expensive equipment
Safeguard operations • Corrosion-resistant housing
No electrical input needed for operation*

DAZIC® 2100 EP and 8100 EP Series Explosion Proof electromechanical rotary motion control zero speed switches monitor the rotary motion of equipment when interlocked as part of a conveyor system, or other shaft-driven process components in hazardous locations.* The switches ensure that if one machine deviates or fails, the switch will:

- Actuate a signal or alarm device
- Break a circuit to a motor
- Make a circuit to start auxiliary equipment
- Make or break a circuit to other electrical devices
- Signal a control station or PLC

When driven from a critical shaft, a **Zero Speed Switch** will engage when a system's normal operating speed:

- Stops due to mechanical failure
- Slows down due to overload
- Changes due to normal machine cycling
- Begins to overspeed
- Reverses rotation

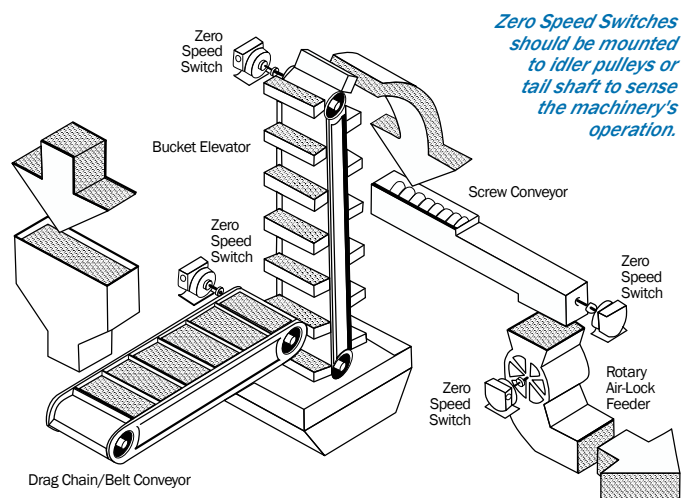

Your DAZIC® Source:



Explosion Proof Zero Speed Switches Specifications

2100 EP Series Explosion Proof Zero Speed Switches

Operating Speeds from 4 to 2000 RPM

Speed Switch Input (RPM) (Application Running Speed)		Approximate Contact Operating Speeds (RPM)			Contact Type		
MIN. RPM	MAX. RPM	Start-Up Trip-Point Upon Initial Speed Switch Acceleration (RPM)	Drop-Out Point On Shaft Speed Loss (RPM)		SPDT Single Pole, Double Throw	DPDT Double Pole, Double Throw	SPDT(2) Direction Indicating
			SLOW LOSS	RAPID LOSS	Model No.	Model No.	Model No.
NOT FIELD ADJUSTABLE							
24	2000	14 to 19	10	0	2120	2122	2130
15	200	8 to 11	Approx. 2 Sec. After Shaft Rotation Failure		2120-1	2122-1	2130-1
8	100	5 to 7	Approx. 3 Sec. After Shaft Rotation Failure		2120-5	2122-5	2130-5
4	50	2 to 3	Approx. 5 Sec. After Shaft Rotation Failure		2120-10	2122-10	2130-10
FIELD ADJUSTABLE							
30	2000	25 to 70	30-40% Below Trip Point	0	2120-A1	2122-A1	2130-A1
75	2000	60 to 140	30-40% Below Trip Point	0	2120-A2	2122-A2	2130-A2
150	2000	125 to 450	30-40% Below Trip Point	0	2120-A3	2122-A3	2130-A3
240	2000	200 to 600	30-40% Below Trip Point	0	2120-A4	2122-A4	2130-A4
15	200	10 to 45	30-40% Below Trip Point	0	2120-A11	2122-A11	2130-A11
7	100	5 to 15	30-40% Below Trip Point	0	2120-A15	2122-A15	2130-A15

8100 EP Series Explosion Proof Zero Speed Switches

Not Field Adjustable

Operating Speeds from 0.5 to 25 RPM

Speed Switch Input (RPM) (Application Running Speed)		Approximate Contact Operating Speeds (RPM)			Contact Type		
MIN. RPM	MAX. RPM	Start-Up Trip-Point Upon Initial Speed Switch Acceleration (RPM)	Drop-Out Point On Shaft Speed Loss (RPM)		SPDT Single Pole, Double Throw	DPDT Double Pole, Double Throw	SPDT(2) Direction Indicating
			SLOW LOSS	RAPID LOSS	Model No.	Model No.	Model No.
1.5	5	1.5	0.5	0	8121	81212	8131
0.5	2.5	0.5	Approx. 4 Sec. After Shaft Rotation Failure		8121-5	81212-5	8131-5
2	25	1.5	Approx. 3-5 Sec. After Shaft Rotation Failure		8122-5	81222-5	8132-5

Mounting Style:

Switches can be mounted in any position but they must be aligned and concentric with the corresponding drive shaft.

Explosion Proof Zero Speed Switches are available with only the Type B - Base Mount.

How to order:

Add the suffix **/EP1** to the model number.

Examples:

Model 2120-A3 = **2120-A3/EP1**

Model 81212-5 = **81212-5/EP1**

2100 EP and 8100 EP Series Explosion Proof Models

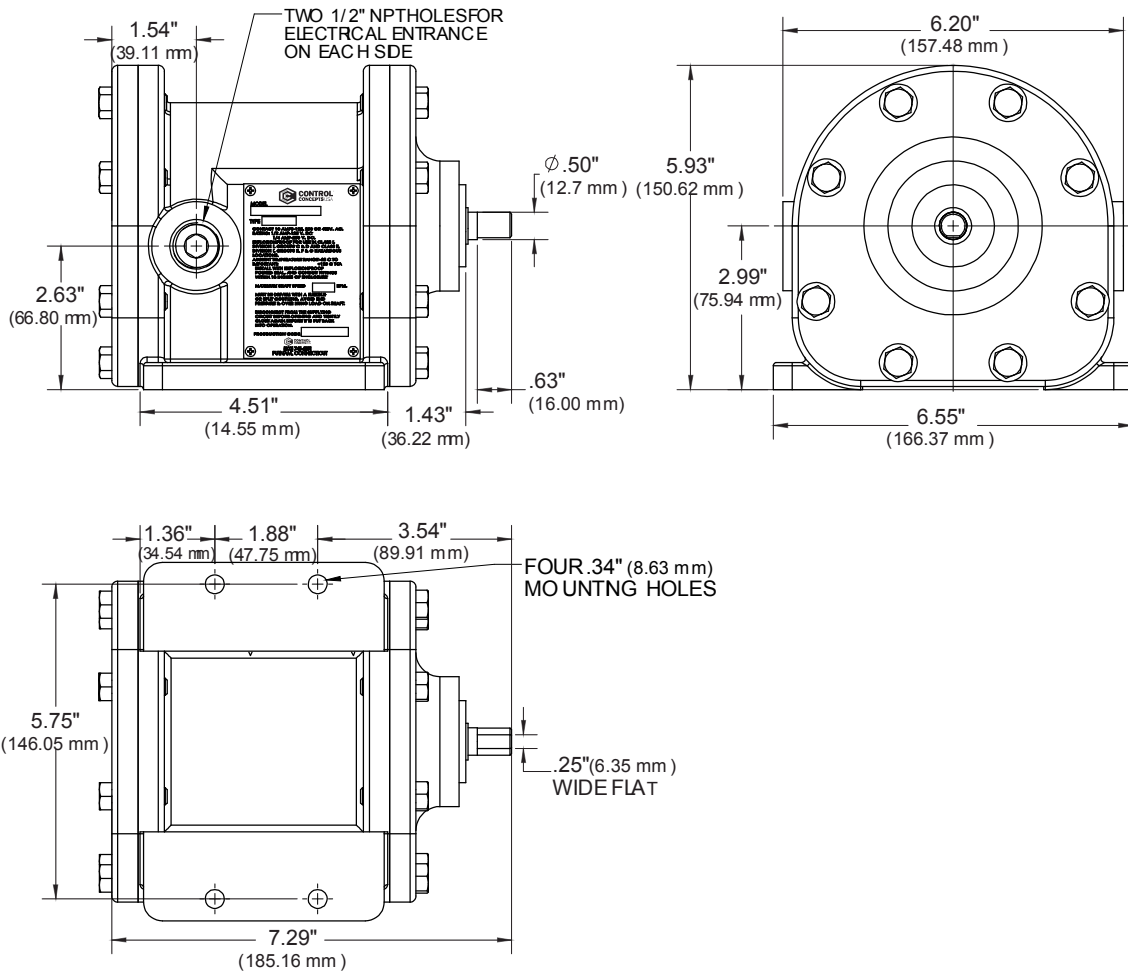

Electrical Wiring Options:

SPDT
Single Pole, Double Throw

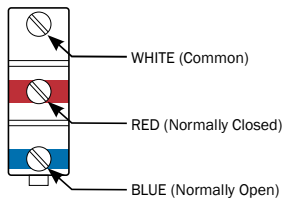

DPDT
Double Pole, Double Throw

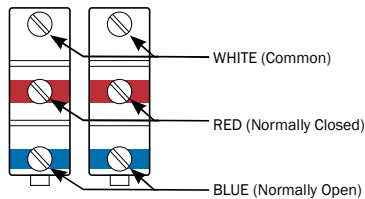

SPDT(2)
Direction Indicating

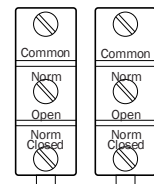

Your DAZIC® Source:

Explosion Proof 2100 EP and 8100 EP Series

Speed Switch devices coupled to a corresponding shaft, must be properly mounted and aligned to avoid putting extra load on motor bearings, which may cause premature failure. The use of installation accessories such as Mounting Brackets and K-Couplings provide a secure foundation and eliminate misalignment connection problems.

Mounting Bracket

When ordering Mounting Brackets, please specify Model MB-2 for 2100 EP and 8100 EP Series Explosion Proof Zero Speed Switches.



Speed Switch attached to a Mounting Bracket



K-Couplings

The K-Coupling® is made of double-loop ELASTACAST® polyurethane elastomeric material assembled to zinc plated steel hubs, which mount to shafts using Allen screws. Motor noise and vibration will be dampened. Bearings will last longer and require less maintenance.

When ordering, make sure the torque requirement is within rating limits, and always include the bore size for both ends of the coupling, which may not be the same. Example: 5801 1/4" x 5/16"

Notes:

- Bore tolerances are AGMA Class 2 – 000 + .002
- All standard coupling hubs are zinc plated steel

Keyways may be obtained on Series 5803 and 5804 couplings for an additional cost.

Standard keyways are: 1/8" for 1/2" dia. shaft;
3/16" for 9/16" and 5/8" dia. shafts

K-Couplings



Available Bore Sizes	Series 5801	Series 5802	Series 5803	Series 5804
3/16" (4.76 mm)	✓			
1/4" (6.35 mm)	✓	✓		
5/16" (7.94 mm)	✓	✓		
3/8" (9.53 mm)	✓	✓	✓	
7/16" (11.11 mm)		✓	✓	
1/2" (12.70 mm)		✓	✓	✓
9/16" (14.29 mm)			✓	✓
5/8" (15.88 mm)			✓	✓
Torque Capacity	0.25 ft-lb 0.34 Nm	1.0 ft-lb (1.36 Nm)	2.33 ft-lb (3.16 Nm)	3.33 ft-lb (4.51 Nm)
Maximum Misalignment	10° angular 3/32" parallel	15° angular 1/8" parallel	15° angular 3/16" parallel	15° angular 1/8" parallel

Mounting Bracket

Approximate Dimensions	Length	Width	Height
Top Plate	10" (254 mm)	7" (177.8 mm)	1/8" thickness (3.175 mm)
Top plate Bracket	7-1/2" (190.5 mm)	4-1/4" (107.95 mm)	2-3/4" (69.85 mm)
Safety Cover	5" (127 mm)	3-1/2" (88.9 mm)	5" (127 mm)

Stub Shaft

Part No.	Shaft Diameter (A)	Thread Size (B)
STSH-500	1/2" (12.70 mm)	1/2-13 UNC-2A
STSH-625	5/8" (15.88 mm)	5/8-11 UNC-2A

Stub Shaft includes one Jam Nut.



STSH-500
Stub Shaft

Your DAZIC® Source: