

1

2

3

4

5

① ✓
 내열도료 KCRUND KP-01
 전면,후면 각각 1mm 코팅

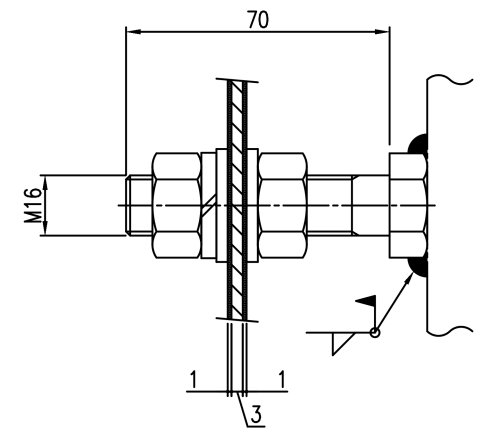
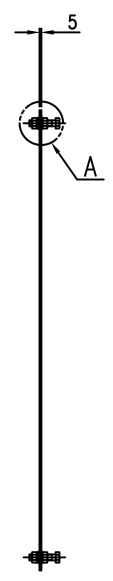
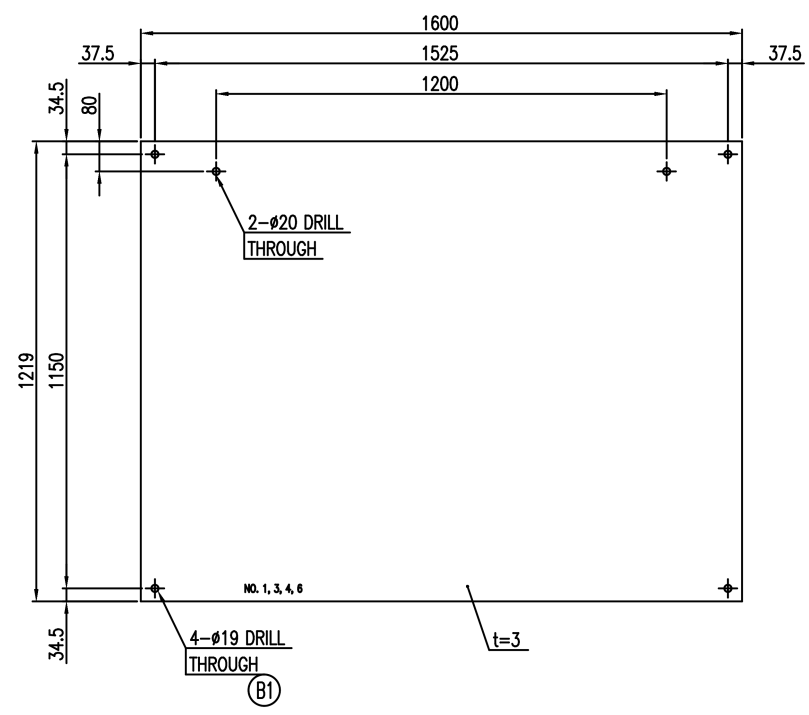

DETAIL A
 (S=2:1)

REMARK'S

1. 전면,후면 각각 1mm 코팅

| | | | | | | |
|-----|---------------------------------|----------|------|----------------|---------|--------------|
| B1 | HEX. BOLT, 2N, 2PW, SW, M16x70L | 10.9 | EA | 4 | 0.2 | 0.8 |
| 1 | MANIFOLD BLOCK t3x1600x1219 | SS275 | EA | 1 | | 45.9 |
| NO. | DESCRIPTION | MAT.(KS) | UNIT | TOTAL QUANTITY | PERUNIT | TOTAL WEIGHT |

| | | | | | | | | | | |
|---------------------|--|------|--|-----------------------|--|-------|---------|----------|----------|------------------------|
| TITLE | | | | | | | | | | |
| Model ; TKP-01-1600 | | | | | | | | | | |
| NO. | | DATE | | REVISION & DISCRPTION | | DRAWN | CHECKED | REVIEWED | APPROVED | DESIGN TEAM |
| | | | | | | | | | | PROJECTION METHOD |
| | | | | | | | | | | THIRD ANGLE PROJECTION |
| | | | | | | | | | | SCALE 1/10 |
| | | | | | | | | | | WORKS |
| | | | | | | | | | | REV. |

YUKEN YUKEN KOREA CO.,LTD.

1

2

3

4

5