

APPROX. H (OPEN)

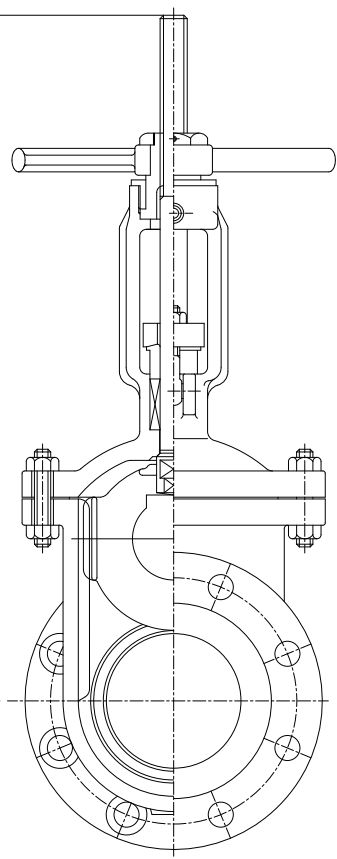

8" & OVER SIZE

BODY MARKING  
 MAKER  
 SIZE  
 RATING  
 MATERIAL  
 HEAT No.

BILL OF MATERIALS

NO.	PART NAME	MATERIAL	Q'TY	REMARK
01	BODY	A351 CF8	1	SEAT STELLITE
02	BONNET	A351 CF8	1	
04	WEDGE	A351 CF8	1	
05	YOKE	A351 CF8	1	8" & OVER
07	STEM	A276 304	1	
09	YOKE SLEEVE	ALBC2	1	
11	GLAND FLANGE	A351 CF8	1	
12	PACKING GLAND	A276 304	1	
14	YOKE CAP	A276 304	1	
15	HANDWHEEL NUT	A276 304	1	
18	HANDWHEEL	A536	1	
31	BONNET BOLT	A193 B8 CL2	1SET	
32	BONNET NUT	A194 8	1SET	
33	YOKE BOLT	A193 B8	4	8" & OVER
34	YOKE NUT	A194 8	4	8" & OVER
35	GLAND BOLT	A193 B8	2	
36	GLAND NUT	A194 8	2	
37	HINGE PIN	A276 304	2	
41	SET SCREW	A193 B8	1	
47	GREASE NIPPLE	CARBON STEEL	1	Zn PLATED
51	PACKING	GRAPHITE	1SET	
56	GASKET	SPW(304/GRAPHITE)	1	

NOTES  
 \* SHELL WALL THICKNESS --- API 603  
 \* FACE-TO-FACE DIMENSIONS --- ASME B16.10  
 \* END FALNGEDIMENSIONS --- ASME B16.5  
 \* HYDROSTATIC TEST PRESSURE : API 598  
 SHELL : 2.9MPa  
 BACK SEAT : 2.09MPa  
 \* PNEUMATIC TEST PRESSURE : API 598  
 SEAT : 0.57 MPa

UNIT : mm

TAG No.	SIZE	L	d	F L A N G E S						H	O	Q'TY	Weight (kg)
				D	C	g	t	f	n-h				
	3/4"	117	19.1	98.6	69.9	42.9	10.4	1.6	4-15.8	190			
	1"	127	25.4	108.0	79.2	50.8	11.2	1.6	4-15.8	210			
	1 1/2"	165	38.1	127.0	98.6	73.2	14.2	1.6	4-15.8	270			
	2"	178	50.8	152.4	120.7	91.9	15.7	1.6	4-19.1	320			
	3"	203	76.2	190.5	152.4	127.0	19.1	1.6	4-19.1	430			
	4"	229	101.6	228.6	190.5	157.2	23.9	1.6	8-19.1	553			
	6"	267	152.4	279.4	241.3	215.9	25.4	1.6	8-22.4	740			
	8"	292	203.2	342.9	298.5	269.7	28.4	1.6	8-22.4	890			
	10"	330	254.0	406.4	362.0	323.9	30.2	1.6	12-25.4	1120			
	12"	356	304.8	482.6	431.8	381.0	31.8	1.6	12-25.4	1325			

△					
△					
△					
NO.	DATE	DESCRIPTION	DRAWN	CHECKED	APPROVED
DRAWN YJ	2021.12.02	TITLE <b>STAINLESS STEEL CLASS 150 CF8 / 304 / HF GATE VALVE</b>			
CHECKED YD					
APPROVED YG					
THIRD ANGLE PROJECTION		DWG.NO. GA15RFCF8HS21-1202-c		REV. 0	
SCALE N/S	A3				