

STANDARD SPECIFICATION

マルチホールケージガイド形調節弁
*MULTI-HOLE CAGE GUIDED TYPE
CONTROL VALVES*

550G SERIES

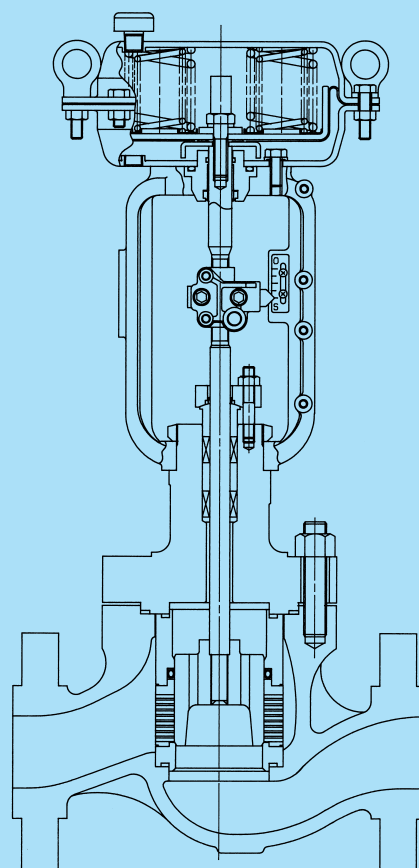

KOSO

KOSOの自動調節弁と計装システム

KOSOは、自動調節弁(コントロールバルブ)のトップメーカーとして高水準にある独自の技術開発力で時代の要請に応え、新世紀へ対応する幅広い製品を揃えるとともに、ISO 9001による品質保証体制のもとで製作した高品質、高信頼のコントロールバルブとそのシステムを提供してまいります。ここに紹介する資料は、**KOSO**コントロールバルブの技術カタログであります。**KOSO**コントロールバルブの選定に御利用下さい。更に詳細な資料が御必要な場合又は、本技術カタログについて不明な点がございましたら最寄りの弊社営業までお問い合わせ下さい。

KOSO's Control Valves and Instrumentation Systems

KOSO, the leading industrial control valve manufacturer with strong research and development capability of its own, has been meeting requirements of the time. Always making available a wide range of product lines that can satisfy the needs of the coming century, **KOSO** is committed to providing control valves, and the systems thereof, of highest quality and reliability, produced under its quality assurance system complying with ISO 9001 standard.

Here **KOSO** presents its technological catalog, introducing various types of **KOSO** control valves, hoping to be of service as you select valves for your specific applications.

If you have questions on this technological catalog or require additional printed materials, please contact our sales representative nearest you.

550G Multi-hole Cage Guided Control Valves

概要

このシリーズは、501Gシリーズのケージガイド形調節弁の標準形ケージの代わりにマルチホール付ケージを組合わせた低騒音並びにアンチキャビテーション対応の調節弁です。

故に、マルチホール付ケージ以外の部品は、501Gシリーズの部品と互換性を持っています。

尚、このシリーズでは、対応できない過酷な流体条件に対してはKOSOのVECTORTM弁を選定して下さい。

GENERAL

This Series provides control valves that meet low noise and anti-cavitation requirements by incorporating a multi-hole type cages, instead of the standard cages, in the 501G Series cage guided control valves. All the parts except the multi-hole cage are interchangeable with the parts of the 501G Series accordingly. For those severe fluid conditions that cannot be covered by this Series, please select KOSO VECTORTM valves.

標準仕様 STANDARD SPECIFICATIONS

弁本体部 BODY

シリーズ Series	550G
弁サイズ Body size	1 ~ 18 (25 ~ 450A)
プラグ形状 Plug form	圧力バランスプラグ形 Pressure balanced plug type
プラグ特性 Characteristics	リニア、モディファイドEQ% Linear, Modified EQ%
トリム材質 Trim materials トリム処理 Trim treatment	標準材質組合わせ及び使用温度・圧力範囲は、表 1 及び図 1 を御参照下さい。 See Table 1 and Fig. 1 for hardening treatment and operating pressure-temperature.
弁本体定格 Body rating	JIS 10K, 20K, 30K, 40K ANSI (JPI) Class 150, 300, 600
弁本体接続 Body connections	フランジ形 (RF, RTJ) 溶接形 (2B以下はSW、3B以上はBWが標準) Flanged (RF, RTJ), Weld ends (SW : 2 and under, BW : 3 and over)
面間寸法 Face to Face dimension	12 ~ 23頁を御参照下さい。 See pages 12 ~ 23.
ボデー及びボンネット材質 Body & Bonnet Material	SCPH2/WCB, SCPH21/WC6, SCPH61/C5, SCPL1/LCB, SCS13A/CF8, SCS14A/CF8M, and other alloy steels.
ボンネット形 Bonnet type	標準形 Standard type : -17 ~ +230 フィン・エクステンション形 Fin-Extension type : -45 ~ -17 未満又は+230 を越える場合 -45 ~ under -17 or over +230 ロング・エクステンション形 Long-Extension type : -196 ~ -45 未満 但し、各材料の使用温度・圧力範囲に注意して下さい。 Note : The allowable operating pressure-temperature limitation for each material.
グランドパッキン Gland packing	テフロンVリング、テフロンカーボンファイバー、グラフォイル、他 使用温度・圧力範囲は、図 3 を御参照下さい。 TFE V-ring, TFE carbon fiber, Grafoil, etc. See Fig. 3 for selection.
ガスケットパッキン Gasket packing	うず巻形ガスケット (テフロン/SUS316、グラフォイル/SUS316) 使用温度・圧力範囲は、図 4 を御参照下さい。 Spiral wound metal, with Grafoil or TFE filler. See Fig. 4 for selection.
塗装色 Painting color	マンセルN - 6 (エポキシ樹脂系) 但し、ステンレス鋼には、塗装しません。 Munsell N-6 (Epoxy resin group) is standard. In the case of stainless steel body, no painting is standard.

駆動部 ACTUATOR

形式 Type	ダイヤフラム式 Diaphragm type	全電子式 Solid State Electronic type		シリンダ式 Pneumatic Cylinder type
	5200LA	3500LC	3600LA	6300LA
仕様 Specification	マルチスプリング形 Multi-spring type	DCモータ・分解能:0.3% DC Motor resolution : 0.3%	ACモータ・分解能:0.4% AC Motor resolution : 0.4%	複動形 Double acting type
用途 Purpose	モジュレーション Modulation	モジュレーション Modulation		モジュレーション Modulation
供給空気圧又は供給電源 Air supply or Power supply	供給空気圧(スプリングレンジ) Air supply (Spring range) 140 (20 ~ 100) kPaG 300 (80 ~ 200) kPaG 340 (80 ~ 200) kPaG 340 (120 ~ 300) kPaG	供給電源 Power supply AC100V 50/60 Hz 入力信号 Input signal 4 ~ 20 mA DC		供給空気圧 Air supply 400 ~ 500 kPaG
接続口 Connection	空気配管口:11 ~ 18頁を御参照下さい。 Air connection : See pages 11 ~ 18.	配線管口 : 21 ~ 22頁を御参照下さい。 Conduit entries : See pages 21 ~ 22.		空気配管口:19 ~ 20頁を御参照下さい。 Air connection : See pages 19 ~ 20.
正作動 Direct action	空気圧増加で弁閉 Air to valve close	入力信号増加で弁閉 Signal increase to valve close		空気又は電気信号により弁開又は弁閉 Valve open or close by air or electric signal.
逆作動 Reverse action	空気圧増加で弁開 Air to valve open	入力信号増加で弁開 Signal increase to valve open		
ヒステリシス Hysteresis	1% FS (ポジショナ付) 1% of FS with positioner	0.5% FS 0.5% of FS	0.8% FS 0.8% of FS	1.5% FS (ポジショナ付) 1.5% of FS with positioner
直線性 Linearity	± 2% FS (ポジショナ付) ± 2% of FS with positioner	± 1% FS ± 1% of FS	± 1% FS ± 1% of FS	± 2% FS (ポジショナ付) ± 2% of FS with positioner
許容周囲温度 Ambient Temp.	- 10 ~ + 70	- 10 ~ + 50		- 20 ~ + 60
標準塗装色 Painting	マンセル Munsell : N 6	メタリックブルー Metallic blue		マンセル Munsell : N 6
オプション Option	E/P、P/Pポジショナ、エアセット、電磁弁、リミットスイッチ、スピード調整器、ロック弁、ロックアップ弁、手動操作機構他 E/P・P/P-Positioner, Air-set, Solenoid valve, Limit switch, Speed controller, Lock valve, Lock-up valve, Manual handle, etc	分解能 : 0.1% スプリットレンジ 開度発信器 (4 ~ 20mA) Resolution : 0.1% Split range, Position transmitter	過負荷ユニット Over load unit	E/P、P/Pポジショナ、エアセット、電磁弁、リミットスイッチ、スピード調整器、ロック弁、ロックアップ弁、手動操作機構他 E/P・P/P-Positioner, Air-set, Solenoid valve, Limit switch, Speed controller, Lock valve, Lock-up valve, Manual handle, etc
		スペースヒータ、手動操作機構、端子箱、耐圧防爆(ケースサイズAのみ) Space heater, Manual handle, Junction box, Explosion proof (Available for Casing size A only)		

性能 PERFORMANCE

Cv 値 Cv value	表 2 を御参照下さい。 See Table 2
流量特性 Flow characteristics	リニア、モデファイド EQ% Linear, Modified EQ%
レンジアビリティ Rangeability	20 : 1 ~ 50 : 1
弁座許容漏洩量 Seat Leakage	表 1 を御参照下さい。 See Table 1 (オプション Option : ANSI CLASS V)
許容差圧 Allowable pressure drops	表 3 を御参照下さい。 See Table 3

付加仕様 (有償) OPTIONAL SPECIAL SPECIFICATIONS (additional cost is required)

弁本体部特殊検査 Special testing for Body	材料検査(ミルシート、液体浸透探傷検査(PT)、放射線透過検査(RT))、流量特性試験、低温試験、蒸気試験 Material certificate, Liquid penetrant testing, Radiographic testing, Flow characteristic testing, Low temperature testing, Stem testing.
弁本体部特殊洗浄 Special cleaning for Body	酸素禁油処理、禁油処理、禁水処理 Oxygen clean, Oil-free, Water-free.
弁本体部及び駆動部特殊仕様 Special specification for Body and Actuator	防砂・防塵仕様、塩害仕様、寒冷仕様、熱帯仕様、禁銅仕様、特殊空気配管及び特殊ジョイント、真空サービス、外気露出部SUSボルトナット、指定塗装色 Sand and Dust proof, Salty environment proof, Cold area proof, Tropical area proof, Not using copper alloy, Special piping and fitting, Vacuum service proof, SUS bolt and nut for exposed parts, Non-standard painting.
認定・認可 Authorization	高圧ガス保安法による認定 Japanese government authorization for high pressure gas.

表1 弁本体とトリムの標準材質組合せ及び使用温度範囲と弁座許容漏洩量

Table 1 BODY/TRIM STANDARD MATERIAL COMBINATION, OPERATING TEMPERATURE AND SEAT LEAKAGE.

トリム材質・処理による使用温度 - 圧力範囲は、図1を御参照下さい。

Trim material/treatment vs operating temperature-pressure range : See Fig. 1

弁座漏洩量をClass Vとする必要がある場合は、お問い合わせ下さい。

When Class V for seat leakage is required, please consult with us.

R.TFE : 強化テフロン Reinforced TFE HT : 熱処理 Heat treatment
 Hcr : ハードクロムメッキ Hard chrome plated SF : ステライトフェース Stellite face
 PH : 析出硬化 Precipitation hardening SS : ステライトシート Stellite seat

表1-1 弁本体材質：炭素鋼

Table 1-1 BODY MATERIAL : CARBON STEEL

弁本体材質 Body material		SCPH2/A216-WCB, SCPH21/A217-WC6, SCPH61/A217-C5, SCPL1/A352-LCB			
ケージ Cage	材質 Material	SCS410			INCONEL
	処理 Treatment	HT			HT
プラグ Plug	材質 Material	SUS410			SFVA F11A/A182-F11
	処理 Treatment	HT			SF
シートリング Seat ring	材質 Material	SUS316 + R.TFE	SUS410		SFVA F11A/A182-F11
	処理 Treatment		HT		SF
バランスシール Balance seal	材質 Material	R.TFE	R.TFE	グラフォイル Grafoil	グラフォイル Grafoil
	バックリング Back ring	SUS316	SUS316		
弁座許容漏洩量 Seat leakage	Class	VI	IV	IV	IV
	Rated Cv x	バブルタイト bubble-tight	0.01%	0.01%	0.01%
使用温度 Operating temperature	SCPH2 / WCB body	- 5 ~ + 200	- 5 ~ + 230	- 5 ~ + 425	- 5 ~ + 425
	SCPH21/WC6 body	- 5 ~ + 200	- 5 ~ + 230	- 5 ~ + 425	- 5 ~ + 538
	SCPH61/C5 body	- 5 ~ + 200	- 5 ~ + 230	- 5 ~ + 425	- 5 ~ + 538
	SCPL1/LCB body	- 45 ~ + 200	- 45 ~ + 230	- 45 ~ + 350	- 45 ~ + 350

表1-2 弁本体材質：ステンレス鋼

Table 1-2 BODY MATERIAL : STAINLESS STEEL

弁本体材質 Body material		SCS13A/A351-CF8 SCS14A/A351-CF8M				
ケージ Cage	材質 Material	SCS316				
プラグ Plug	材質 Material	SUS316	SUS316	SUS316	SUS316	SUS316
	処理 Treatment	Hcr	Hcr+SS	SF	Hcr+SS	SF
シートリング Seat ring	材質 Material	SUS316+R.TFE	SUS316	SUS316	SUS316	SUS316
	処理 Treatment		SS	SF	SS	SF
バランスシール Balance seal	材質 Material	R.TFE	R.TFE	R.TFE	Grafoil	Grafoil
	バックリング Back ring	SUS316	SUS316	SUS316		
弁座許容漏洩量 Seat leakage	Class	VI	IV	IV	IV	IV
	Rated Cv x	bubble-tight	0.01%	0.01%	0.01%	0.01%
使用温度 Operating Temp.		- 75 ~ + 200	- 196 ~ + 230	- 196 ~ + 230	- 196 ~ + 538	- 196 ~ + 538

* 流体温度が - 75 以下の場合は、バランスシール材質：フロロロイG、バックリング材質：エルジロイとなります。
 When the fluid temperature is below - 75 , the materials for the balance seal and the back ring will be Fluoroloy G and Elgiloy, respectively.

図1 トリム材質組合せに対する使用温度と差圧

Fig. 1 OPERATING TEMPERATURE AND PRESSURE DROPS FOR TRIM MATERIAL COMBINATIONS

図1-1 Fig. 1-1

ケージ	Cage	SUS410 HT
プラグ	Plug	SUS410 HT
シートリング	Seat ring	SUS410 HT



図1-2 Fig. 1-2

ケージ	Cage	INCONEL HT
プラグ	Plug	A182-F11 SF
シートリング	Seat ring	A182-F11 SF

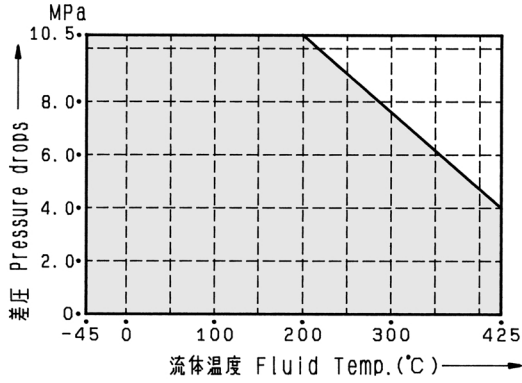

図1-3 Fig. 1-3

ケージ	Cage	SUS316	SUS316
プラグ	Plug	SUS316 SF	SUS316 Hcr + SS
シートリング	Seat ring	SUS316 SF	SUS316 SS

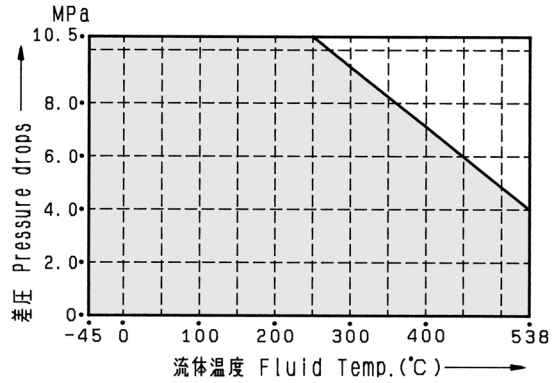

図1-4 Fig. 1-4

ケージ	Cage	SUS410	SUS316
プラグ	Plug	SUS410	SUS316 Hcr
シートリング	Seat ring	強化テフロン Reinforced TFE	

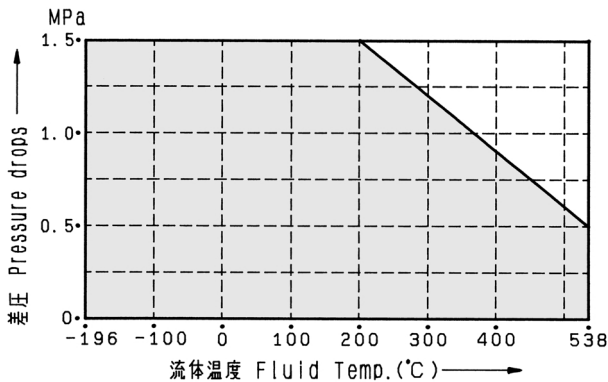

図2 バランスシール使用温度・圧力範囲

Fig. 2 BALANCE SEAL PRESSURE-TEMPERATURE RATINGS

図2-1 強化テフロン/SUS316

Fig. 2-1 REINFORCED TFE/SUS316

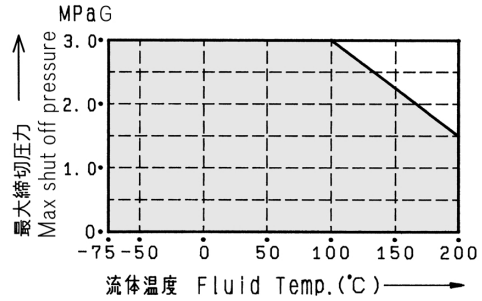

図2-2 グラフォイル

Fig. 2-2 GRAFOIL

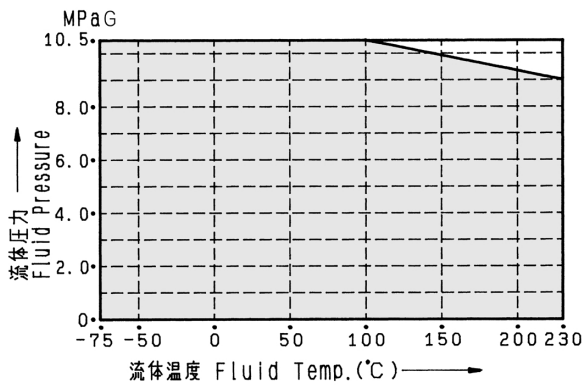

図2-3 フロロロイG/エルジロイ

Fig. 2-3 FLUOROLOY G/ELGILOY

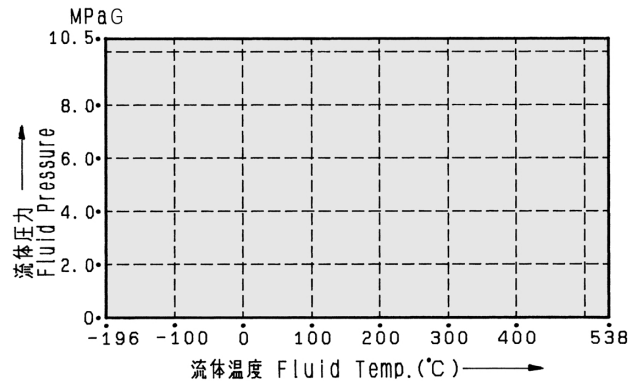

図3 グランドパッキン使用温度・圧力範囲

Fig. 3 GLAND PACKING PRESSURE-TEMPERATURE RATINGS

図3-1 強化テフロンVリング

Fig. 3-1 REINFORCED TFE V-RING

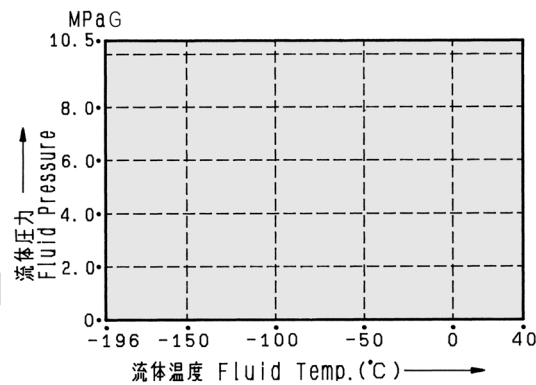

図3-2 テフロンカーボンファイバー

Fig. 3-2 TFE CARBON FIBER

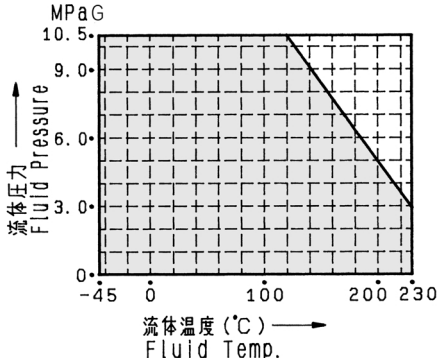

図3-3 グラフォイル

Fig. 3-3 GRAFOIL

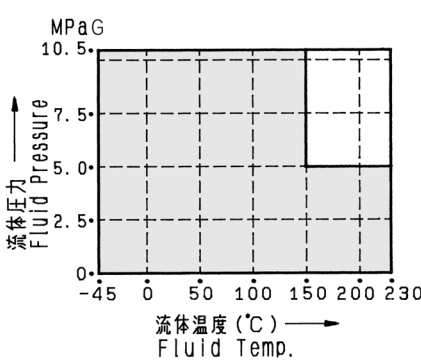

図4 ガasketパッキン使用温度・圧力範囲

Fig. 4 GASKET PACKING PRESSURE-TEMPERATURE RATINGS

図4-1 グラフォイル/SUS316

Fig. 4-1 GRAFOIL/SUS316

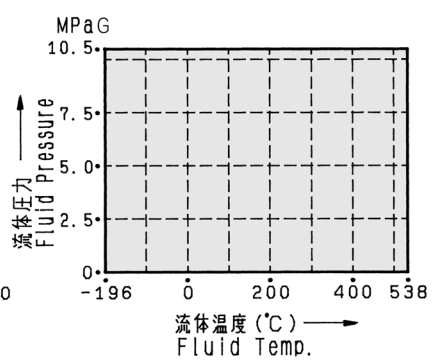

図4-2 テフロン/SUS316

Fig. 4-2 TFE/SUS316

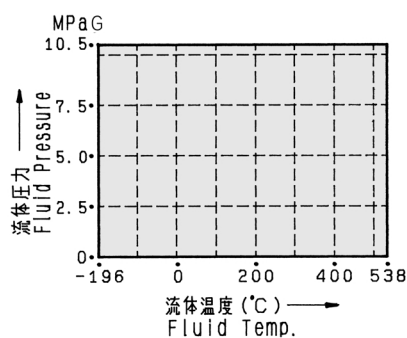

表2 Cv値及びストローク：リニア

Table 2 Cv VALUE AND STROKE: Linear

弁サイズ Body size inch(mm)	プラグサイズ Plug size inch(mm)	Cv値 Cv value	ストローク Stroke mm	弁サイズ Body size inch(mm)	プラグサイズ Plug size inch(mm)	Cv値 Cv value	ストローク Stroke mm
1 (25)	5/8	6.3	20	8 (200)	6 (150)	405	60
	1 (25)	14	20		8 (200)	690	80
1 1/2 (40)	1 (25)	17	20	10 (250)	8 (200)	700	80
	1 1/2 (40)	34	25		10 (250)	910	90
2 (50)	1 1/2 (40)	43	25	12 (300)	10 (250)	930	90
	2 (50)	54	30		12 (300)	1230	100
3 (80)	2 (50)	69	30	14 (350)	12 (300)	1270	100
	3 (80)	120	40		14 (350)	1560	130
4 (100)	3 (80)	130	40	16 (400)	14 (350)	1630	130
	4 (100)	200	50		16 (400)	1890	150
6 (150)	4 (100)	230	50	18 (450)	16 (400)	1890	150
	6 (150)	390	60		18 (450)	2220	150

図5 弁本体部構造

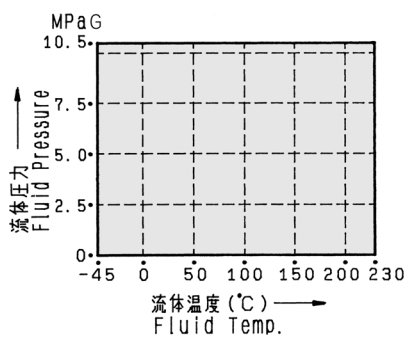
Fig. 5 BODY SECTION VIEW

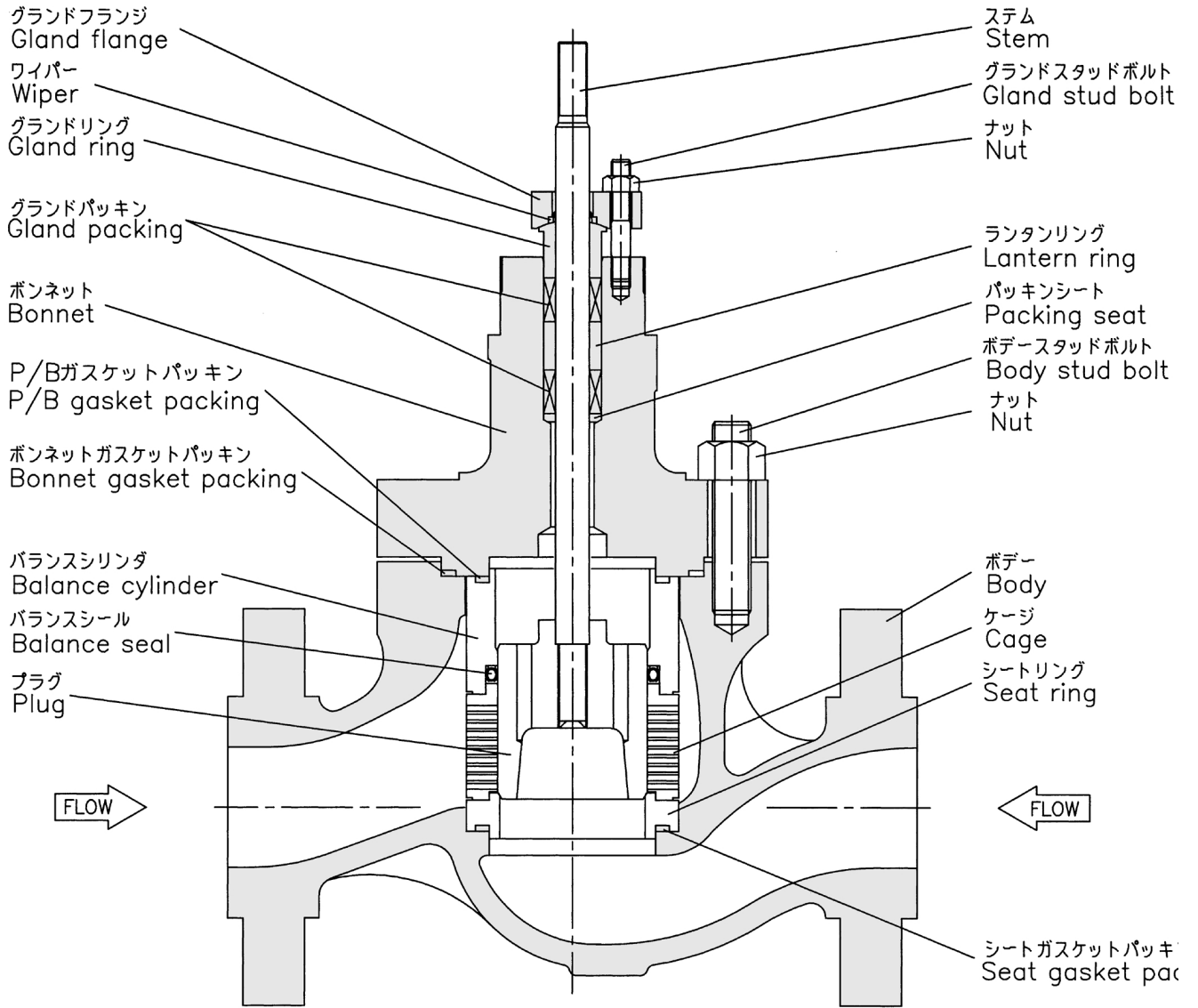

FLOW TO CLOSE : (液流体)
(Over Plug Flow) : (Liquid)

FLOW TO OPEN : (スチーム及び,ガス流体)
(Under Plug Flow) : (Steam or Gas)

表3 許容差圧 (単位: MPa)

Table 3 ALLOWABLE PRESSURE DROPS (UNIT : MPa)

DA : 正作動 (空気圧増加で弁閉) Direct action (Air to valve shut)

RA : 逆作動 (空気圧増加で弁開) Reverse action (Air to valve open)

表3-1 ダイアフラム駆動部 (5200LA) / パッキン : 強化テフロンVリング、テフロンカーボンファイバー

Table 3-1 DIAPHRAGM ACTUATOR (5200LA)/PACKING : REINFORCED TFE V-RING, TFE CARBON FIBER

駆動部 サイズ Actuator size	供給空気圧 Air supply (オフバランス) Off balance kPaG	スプリングレンジ Spring range kPaG	シートリング Seat ring	バランスシール : 強化テフロン/SUS316 Balance seal : Reinforced TFE/SUS316											
				プラグサイズ Plug size (inch)											
				5/8	1	1 1/2	2	3	4	6	8	10	12		
218	140(20)	DA & RA 20~100	Metal Seat	0.36											
			Soft Seat	0.36											
	300(80)	DA & RA 80~200	Metal Seat	6.95	6.66										
			Soft Seat	3.0	3.0										
	340(120)	DA : 80~200 RA : 120~300	Metal Seat	9.89	9.89										
			Soft Seat	3.0	3.0										
270	140(20)	DA & RA 20~100	Metal Seat	2.05	0.57										
			Soft Seat	2.05	0.57										
	300(80)	DA & RA 80~200	Metal Seat	9.89	9.89	8.82	6.27								
			Soft Seat	3.0	3.0	3.0	3.0								
	340(120)	DA : 80~200 RA : 120~300	Metal Seat	9.89	9.89	9.89	9.89								
			Soft Seat	3.0	3.0	3.0	3.0								
350	140(20)	DA & RA 20~100	Metal Seat	4.99	4.6	1.17									
			Soft Seat	3.0	3.0	1.17									
	300(80)	DA & RA 80~200	Metal Seat	9.89	9.89	9.89	9.89								
			Soft Seat	3.0	3.0	3.0	3.0								
450	140(20)	DA & RA 20~100	Metal Seat			5.39	3.52								
			Soft Seat			3.0	3.0								
	300(80)	DA & RA 80~200	Metal Seat			9.89	9.89	9.89	9.89	7.64	5.0				
			Soft Seat			3.0	3.0	3.0	3.0	3.0	3.0				
650	300(80)	DA & RA 80~200	Metal Seat					9.89	9.89	9.89	9.89	9.89	9.62		
			Soft Seat					3.0	3.0	3.0	3.0	3.0	3.0	3.0	

表3-2 ダイアフラム駆動部 (5200LA) / グランドパッキン : グラフォイル

Table 3-2 DIAPHRAGM ACTUATOR (5200LA)/GLAND PACKING : GRAFOIL

駆動部 サイズ Actuator size	供給空気圧 Air supply (オフバランス) Off balance kPaG	スプリングレンジ Spring range kPaG	シートリング Seat ring	バランスシール : グラフォイル Balance seal : GRAFOIL											
				プラグサイズ Plug size (inch)											
				5/8	1	1 1/2	2	3	4	6	8	10	12		
270	140(20)	DA & RA 20~100	Metal Seat												
			Soft Seat												
	300(80)	DA & RA 80~200	Metal Seat	8.33											
			Soft Seat	3.0											
	340(120)	DA : 80~200 RA : 120~300	Metal Seat	8.33											
			Soft Seat	3.0											
350	140(20)	DA & RA 20~100	Metal Seat												
			Soft Seat												
	300(80)	DA & RA 80~200	Metal Seat	8.33	8.33	8.33	8.33								
			Soft Seat	3.0	3.0	3.0	3.0								
450	140(20)	DA & RA 20~100	Metal Seat												
			Soft Seat												
	300(80)	DA & RA 80~200	Metal Seat			8.33	8.33	8.33	7.85						
			Soft Seat			3.0	3.0	3.0	3.0						
650	300(80)	DA & RA 80~200	Metal Seat					8.33	8.33	8.33	8.33	5.15			
			Soft Seat					3.0	3.0	3.0	3.0	3.0	3.0		

表3-3 複動形シリンダ式駆動部 (6300LA) / グランドパッキン : 強化テフロンVリング、テフロンカーボンファイバー
 Table 3-3 DOUBLE ACTING CYLINDER ACTUATOR/GLAND PACKING : REINFORCED TFE V-RING, TFE CARBON FIBER

駆動部サイズ Actuator size	供給空気圧 Air supply kPaG	シートリング Seat ring	バランスシール : 強化テフロン / SUS316 Balance seal : Reinforced TFE / SUS316							
			プラグサイズ Plug size (inch)							
			4	6	8	10	12	14	16	18
200	400	Metal Seat	9.89	9.89	9.89					
		Soft Seat	3.0	3.0	3.0					
	500	Metal Seat	9.89	9.89	9.89					
		Soft Seat	3.0	3.0	3.0					
300	400	Metal Seat	9.89	9.89	9.89	9.89	9.89			
		Soft Seat	3.0	3.0	3.0	3.0	3.0			
	500	Metal Seat	9.89	9.89	9.89	9.89	9.89			
		Soft Seat	3.0	3.0	3.0	3.0	3.0			
450	400	Metal Seat		9.89	9.89	9.89	9.89	9.89	9.89	9.89
		Soft Seat		3.0	3.0	3.0	3.0	3.0	3.0	3.0
	500	Metal Seat		9.89	9.89	9.89	9.89	9.89	9.89	9.89
		Soft Seat		3.0	3.0	3.0	3.0	3.0	3.0	3.0
600	400	Metal Seat				9.89	9.89	9.89	9.89	9.89
		Soft Seat				3.0	3.0	3.0	3.0	3.0
	500	Metal Seat				9.89	9.89	9.89	9.89	9.89
		Soft Seat				3.0	3.0	3.0	3.0	3.0

表 3-4 複動形シリンダ式駆動部 (6300LA) / グランドパッキン : グラフォイル

Table 3-4 DOUBLE ACTING CYLINDER ACTUATOR/GLAND PACKING : GRAFOIL

駆動部サイズ Actuator size	供給空気圧 Air supply kPaG	シートリング Seat ring	バランスシール : グラフォイル Balance seal : GRAFOIL							
			プラグサイズ Plug size (inch)							
			4	6	8	10	12	14	16	18
300	400	Metal Seat	8.33							
		Soft Seat	3.0							
	500	Metal Seat	8.33							
		Soft Seat	3.0							
450	400	Metal Seat		8.33	8.33	8.33	8.33	8.33	8.33	8.33
		Soft Seat		3.0	3.0	3.0	3.0	3.0	3.0	3.0
	500	Metal Seat		8.33	8.33	8.33	8.33	8.33	8.33	8.33
		Soft Seat		3.0	3.0	3.0	3.0	3.0	3.0	3.0
600	400	Metal Seat				8.33	8.33	8.33	8.33	8.33
		Soft Seat				3.0	3.0	3.0	3.0	3.0
	500	Metal Seat				8.33	8.33	8.33	8.33	8.33
		Soft Seat				3.0	3.0	3.0	3.0	3.0

表3-5 電子式駆動部 (3500LC、3600LA) / グランドパッキン : 強化テフロンVリング、テフロンカーボンファイバー

Table 3-5 SOLID STATE ELECTRONIC ACTUATOR (3500LC, 3600LA)/GLAND PACKING : REINFORCED TFE V-RING, TFE CARBON FIBER

駆動部サイズ Actuator size	シートリング Seat ring	バランスシール : 強化テフロン / SUS316 Balance seal : Reinforced TFE/SUS316									
		プラグサイズ Plug size (inch)									
		5/8	1	1½	2	3	4	6	8	10	12
35A2LC 36A2LA	Metal Seat	9.01	8.63	5.39	3.23						
	Soft Seat	3.0	3.0	3.0	3.0						
35B1LC 36B1LA	Metal Seat	9.89	9.89	9.89	8.33						
	Soft Seat	3.0	3.0	3.0	3.0						
35B2LC 36B2LA	Metal Seat				9.89	9.89	7.25	3.0			
	Soft Seat				3.0	3.0	3.0	3.0			
36C1LA	Metal Seat					9.89	9.89	5.78			
	Soft Seat					3.0	3.0	3.0			
36C2LA	Metal Seat						9.89	9.89	7.74	5.59	3.62
	Soft Seat						3.0	3.0	3.0	3.0	3.0

表3-6 電子式駆動部 (3500LC、3600LA) / グランドパッキン : グラフォイル

Table 3-6 SOLID STATE ELECTRONIC ACTUATOR (3500LC, 3600LA)/GLAND PACKING : GRAFOIL

駆動部サイズ Actuator size	シートリング Seat ring	バランスシール : グラフォイル Balance seal : GRAFOIL									
		プラグサイズ Plug size (inch)									
		5/8	1	1½	2	3	4	6	8	10	12
35B1LC 36B1LA	Metal Seat	8.33	8.33	0.66							
	Soft Seat	3.0	3.0	0.66							
35B2LC 36B2LA	Metal Seat			8.33	8.33	1.07					
	Soft Seat			3.0	3.0	1.07					
36C1LA	Metal Seat				9.89	7.25	2.45				
	Soft Seat				3.0	3.0	2.45				
36C2LA	Metal Seat						8.33	0.79			
	Soft Seat						3.0	0.79			

GLOBE VALVE 550G DIRECT ACTION

*1 AIR EXHAUST POSITION FOR $\phi 218$ & $\phi 270$.
 *2 AIR EXHAUST POSITION FOR $\phi 350$ & $\phi 450$.

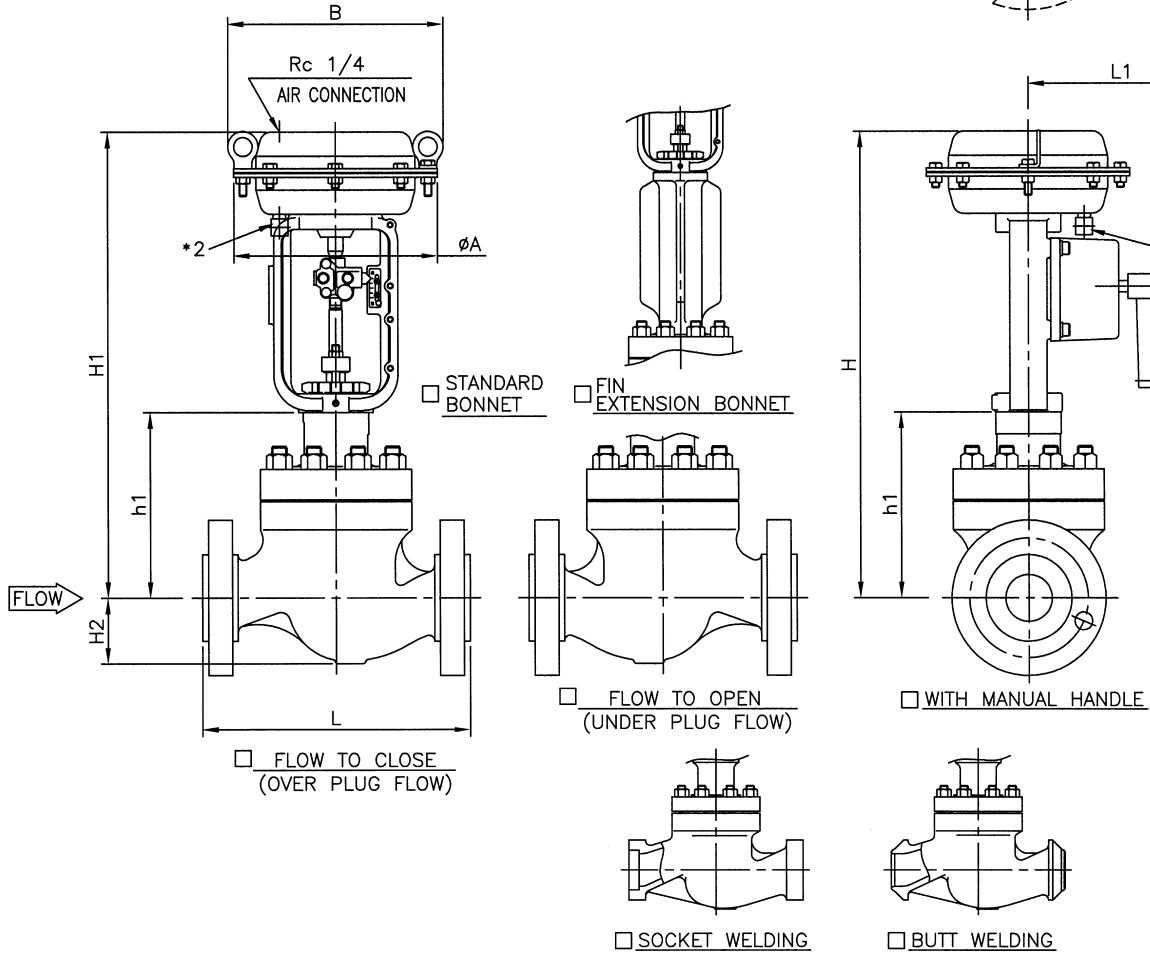
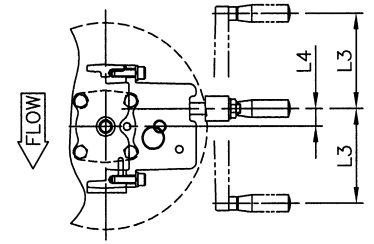

DIMENSIONS

UNIT : mm

CODE NO.	BODY SIZE	FACE TO FACE :L							H2	STANDARD BONNET		FIN EXTENSION BONNET		ACTUATOR					CODE NO.
		ANSI 150#RF	ANSI 300#RF	ANSI 600#RF	ANSI 300#SW	ANSI 300#RTJ	ANSI 600#SW	ANSI 600#RTJ		h1	H1	h1	H1	WITH MANUAL HANDLE					
		JPI 150#RF	JPI 300#RF	JPI 600#RF	ANSI 300#BW	JPI 300#RTJ	ANSI 600#BW	JPI 600#RTJ						A	B	L1	L3	L4	
01	1" (25A)	184	197	210	210	210	210	210	47	157	455	257	555	<input type="checkbox"/> 218	231	196	65	18.5	5221LA
		555	655	<input type="checkbox"/> 270	283	230	100	27.5			5227LA								
		590	690	<input type="checkbox"/> 350	367	230	100	27.5			5235LA								
93	1 1/2" (40A)	222	235	251	251	248	251	251	60	175	475	325	625	<input type="checkbox"/> 218	231	196	65	18.5	5221LA
		570	720	<input type="checkbox"/> 270	283	230	100	27.5			5227LA								
		605	755	<input type="checkbox"/> 350	367	230	100	27.5			5235LA								
		670	820	<input type="checkbox"/> 450	472	336	160	32			524SLA								
		595	745	<input type="checkbox"/> 270	283	230	100	27.5			5227LA								
02	2" (50A)	254	267	286	286	283	286	289	70	196	630	346	780	<input type="checkbox"/> 350	367	230	100	27.5	5235LA
		695	845	<input type="checkbox"/> 450	472	336	160	32			524SLA								
		600	750	<input type="checkbox"/> 270	283	230	100	27.5			5227LA								
03	3" (80A)	298	317	337	317	333	337	340	98	201	635	351	785	<input type="checkbox"/> 350	367	230	100	27.5	5235LA
		700	850	<input type="checkbox"/> 450	472	336	160	32			524SLA								
		352	368	394	368	384	394	397			113		275	770	425	920	<input type="checkbox"/> 450	472	336

* FLANGE IS ACCORDING TO THE STANDARD WHICH IS DESCRIBED ON SPECIFICATION SHEET.

NOTE:

DRAWING No.

E-550G-5200LA-D-N
S

REV.

E

KOSO

GLOBE VALVE 550G REVERSE ACTION

*1 AIR CONNECTION POSITION FOR $\phi 218$ & $\phi 270$.
 *2 AIR CONNECTION POSITION FOR $\phi 350$ & $\phi 450$.

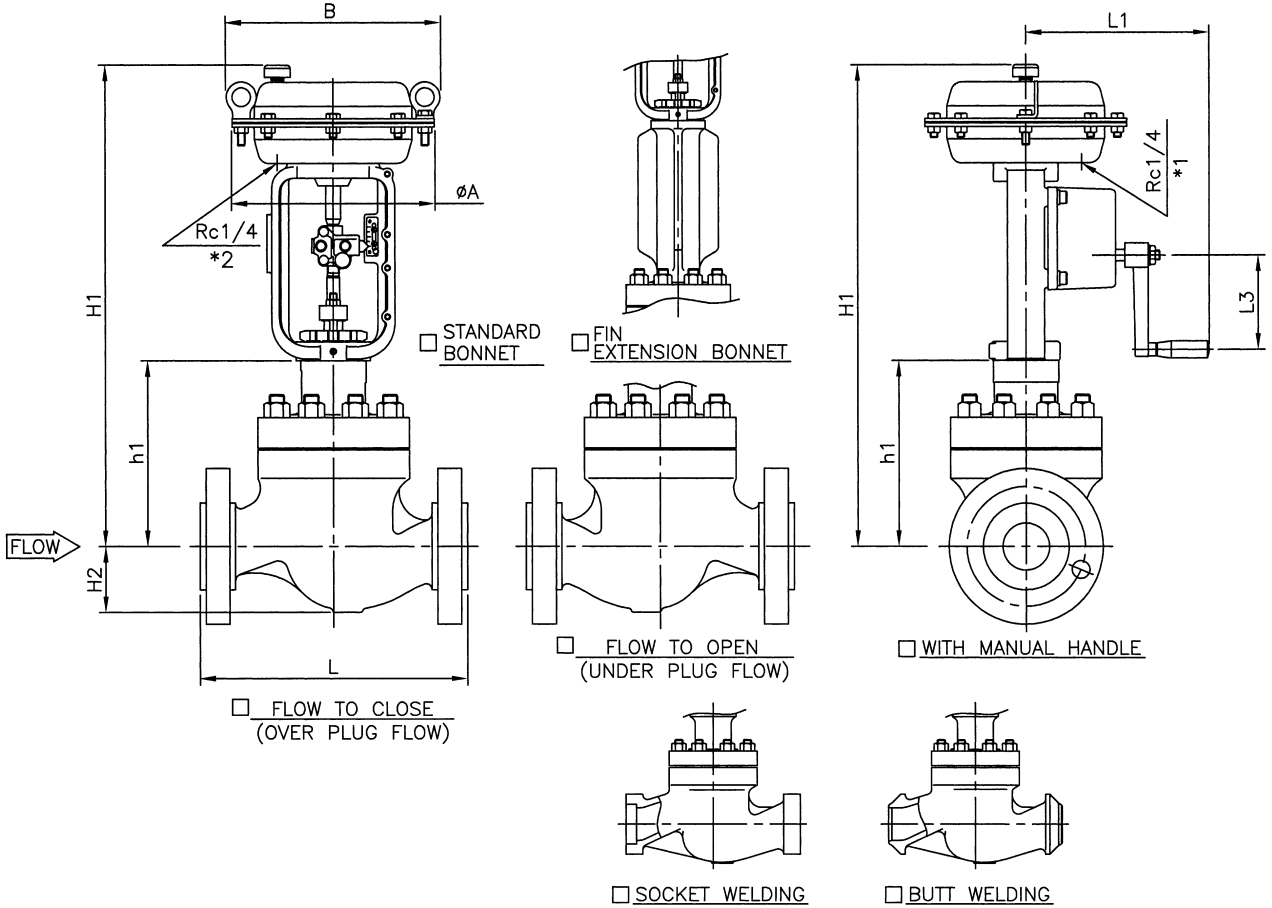
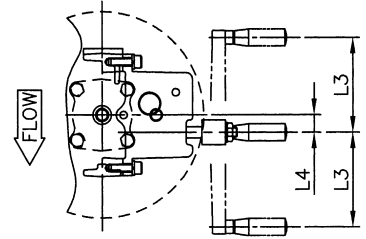

DIMENSIONS

UNIT : mm

BODY SIZE	FACE TO FACE :L								STANDARD BONNET		FIN EXTENSION BONNET		ACTUATOR					
	ANSI 150#RF	ANSI 300#RF	ANSI 600#RF	ANSI 300#SW	ANSI 300#RTJ	ANSI 600#SW	ANSI 600#RTJ	H2	h1	H1	h1	H1	SIZE		WITH MANUAL HANDLE			CODE NO.
	JPI 150#RF	JPI 300#RF	JPI 600#RF	JPI 300#BW	JPI 300#RTJ	JPI 600#BW	JPI 600#RTJ						A	B	L1	L3	L4	
01 $1''$ (25A)	184	197	210	210	210	210	210	47	157	495	257	595	\square 218	231	196	65	18.5	5221LA
										595		695	\square 270	283	230	100	27.5	5227LA
										630		730	\square 350	367	230	100	27.5	5235LA
93 $1\frac{1}{2}''$ (40A)	222	235	251	251	248	251	251	60	175	515	325	665	\square 218	231	196	65	18.5	5221LA
										610		760	\square 270	283	230	100	27.5	5227LA
										645		795	\square 350	367	230	100	27.5	5235LA
										710		860	\square 450	472	336	160	32	524SLA
										635		785	\square 270	283	230	100	27.5	5227LA
02 $2''$ (50A)	254	267	286	286	283	286	289	70	196	670	346	820	\square 350	367	230	100	27.5	5235LA
										735		885	\square 450	472	336	160	32	524SLA
										640		790	\square 270	283	230	100	27.5	5227LA
03 $3''$ (80A)	298	317	337	317	333	337	340	98	201	675	351	825	\square 350	367	230	100	27.5	5235LA
										740		890	\square 450	472	336	160	32	524SLA
04 $4'' \times 3''$ (100A X 80A)	352	368	394	368	384	394	397	113	275	810	425	960	\square 450	472	336	160	32	524SLA

* FLANGE IS ACCORDING TO THE STANDARD WHICH IS DESCRIBED ON SPECIFICATION SHEET.

NOTE:

DRAWING No.

E-550G-5200LA-R-N
S

REV.

E

KOSO

GLOBE VALVE 550G REVERSE ACTION

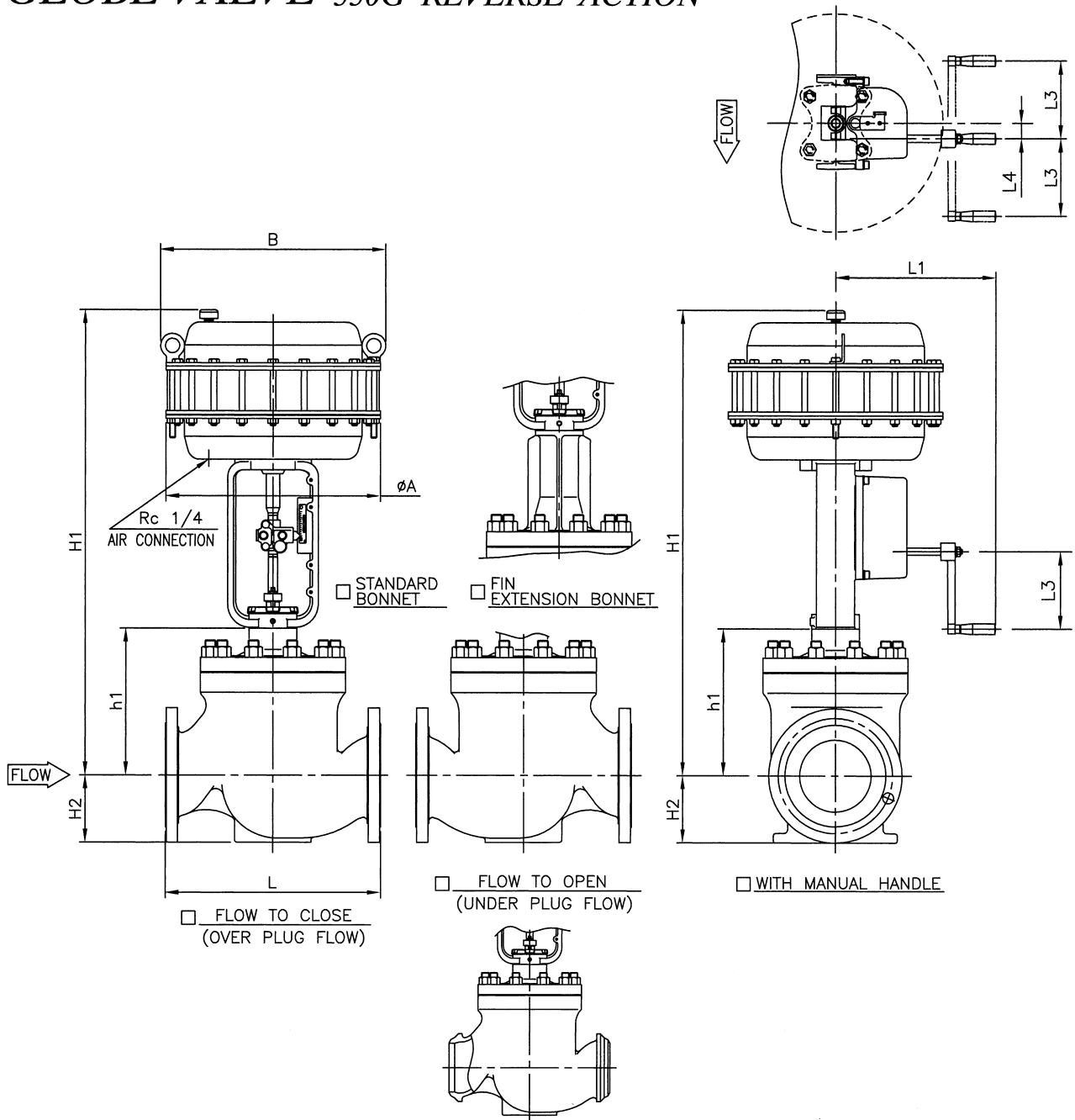

DIMENSIONS

BUTT WELDING

UNIT : mm

BODY SIZE	FACE TO FACE :L								<input type="checkbox"/> STANDARD BONNET		<input type="checkbox"/> FIN EXTENSION BONNET		ACTUATOR					
	<input type="checkbox"/> ANSI 150#RF <input type="checkbox"/> JPI 150#RF <input type="checkbox"/> JIS 10k RF	<input type="checkbox"/> ANSI 300#RF <input type="checkbox"/> JPI 300#RF <input type="checkbox"/> JIS 20k RF <input type="checkbox"/> JIS 30k RF	<input type="checkbox"/> ANSI 600#RF <input type="checkbox"/> JPI 600#RF <input type="checkbox"/> JIS 40k RF	<input type="checkbox"/> ANSI 300#BW <input type="checkbox"/> JPI 300#BW	<input type="checkbox"/> ANSI 300#RTJ <input type="checkbox"/> JPI 300#RTJ	<input type="checkbox"/> ANSI 600#BW <input type="checkbox"/> JPI 600#BW	<input type="checkbox"/> ANSI 600#RTJ <input type="checkbox"/> JPI 600#RTJ					SIZE	WITH MANUAL HANDLE			CODE NO.		
							H2	h1	H1	h1	H1	A	B	L1	L3		L4	
04 <input type="checkbox"/> 4" (100A)	352	368	394	368	384	394	397	113	275	950	425	1100	450	472	336	160	32	524LLA
06 <input type="checkbox"/> 6" (150A)	451	473	508	473	489	508	511	144	305	980	455	1130	450	472	336	160	32	524LLA
08 <input type="checkbox"/> 8" (200A)	543	568	610	568	584	610	613	185	365	1060	515	1210	450	472	336	160	32	524LLA
10 <input type="checkbox"/> 10"X8" (250AX200A)	673	708	752	708	724	752	756	225	420	1115	570	1265	450	472	336	160	32	524LLA

* FLANGE IS ACCORDING TO THE STANDARD WHICH IS DESCRIBED ON SPECIFICATION SHEET.

NOTE:

DRAWING No.

E-550G-524LLA-R-^N_S

REV.

D

KOSO

GLOBE VALVE 550G DIRECT ACTION

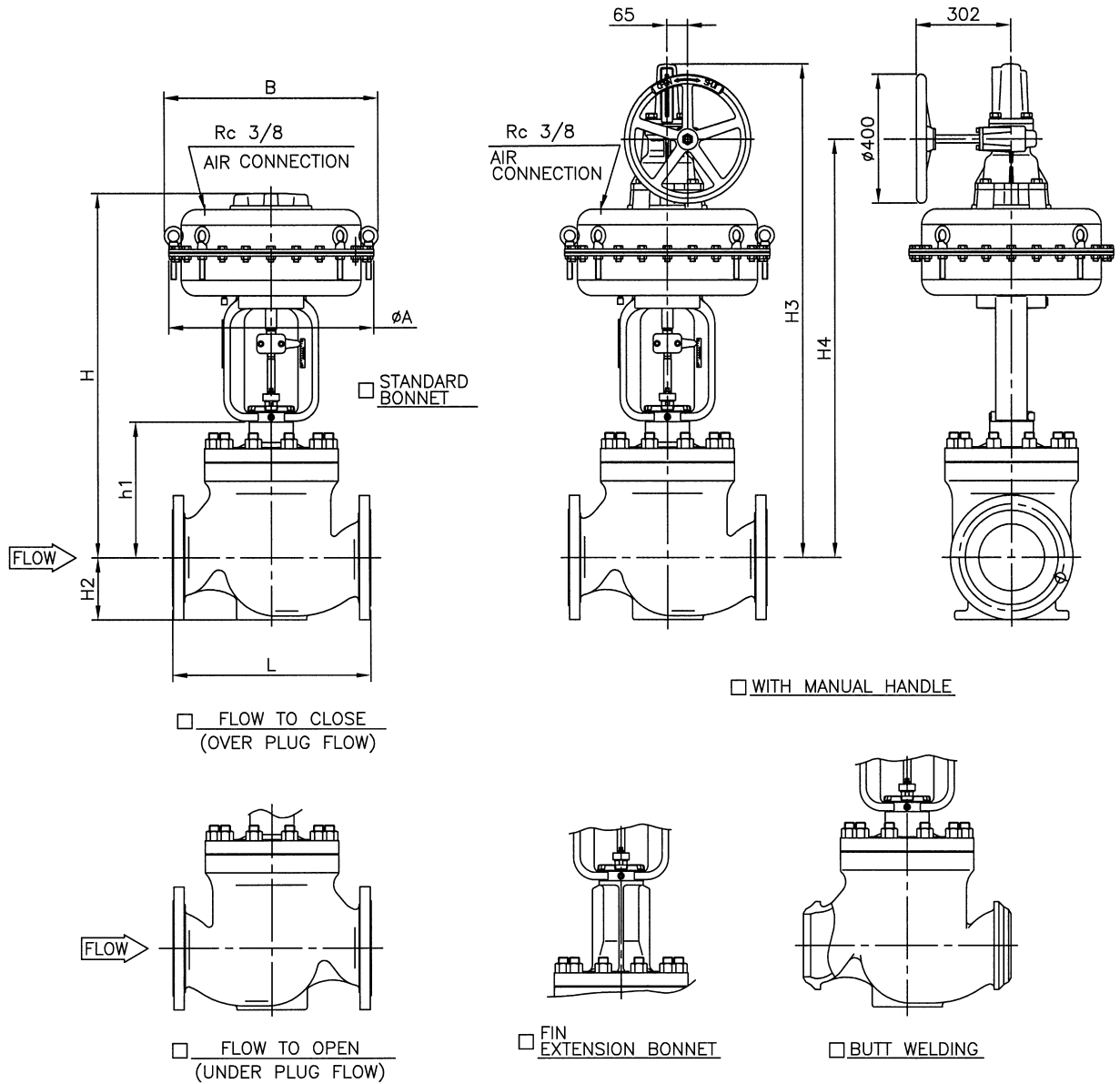

DIMENSIONS

UNIT : mm

CODE NO.	BODY SIZE	FACE TO FACE :L								ACTUATOR				ACTUATOR				CODE NO.		
		ANSI 150#RF	ANSI 300#RF	ANSI 600#RF	ANSI 300#BW	ANSI 300#RTJ	ANSI 600#BW	ANSI 600#RTJ	STANDARD BONNET	FIN EXTENSION BONNET	WITH MANUAL HANDLE									
		JPI	JPI	JPI	JPI	JPI	JPI	JPI			ST,D BONNET	FIN/EXT BONNET								
		10k RF	20k RF	40k RF	300#BW	300#RTJ	600#BW	600#RTJ	H2	h1	H1	h1	H1	A	B	H3	H4		H3	H4
04	4" (100A)	352	368	394	368	384	394	397	113	305	1025	455	1175	650	678	1425	1190	1575	1340	526SLA
06	6" (150A)	451	473	508	473	489	508	511	144	327	1045	477	1195	650	678	1445	1215	1595	1365	526SLA
08	8"X6" (200AX150A)	543	568	610	568	584	610	613	185	365	1085	515	1235	650	678	1485	1250	1635	1400	526SLA

* FLANGE IS ACCORDING TO THE STANDARD WHICH IS DESCRIBED ON SPECIFICATION SHEET.

NOTE:

DRAWING No.
E-550G-526SLA-D-N
H

REV.
C

GLOBE VALVE 550G REVERSE ACTION

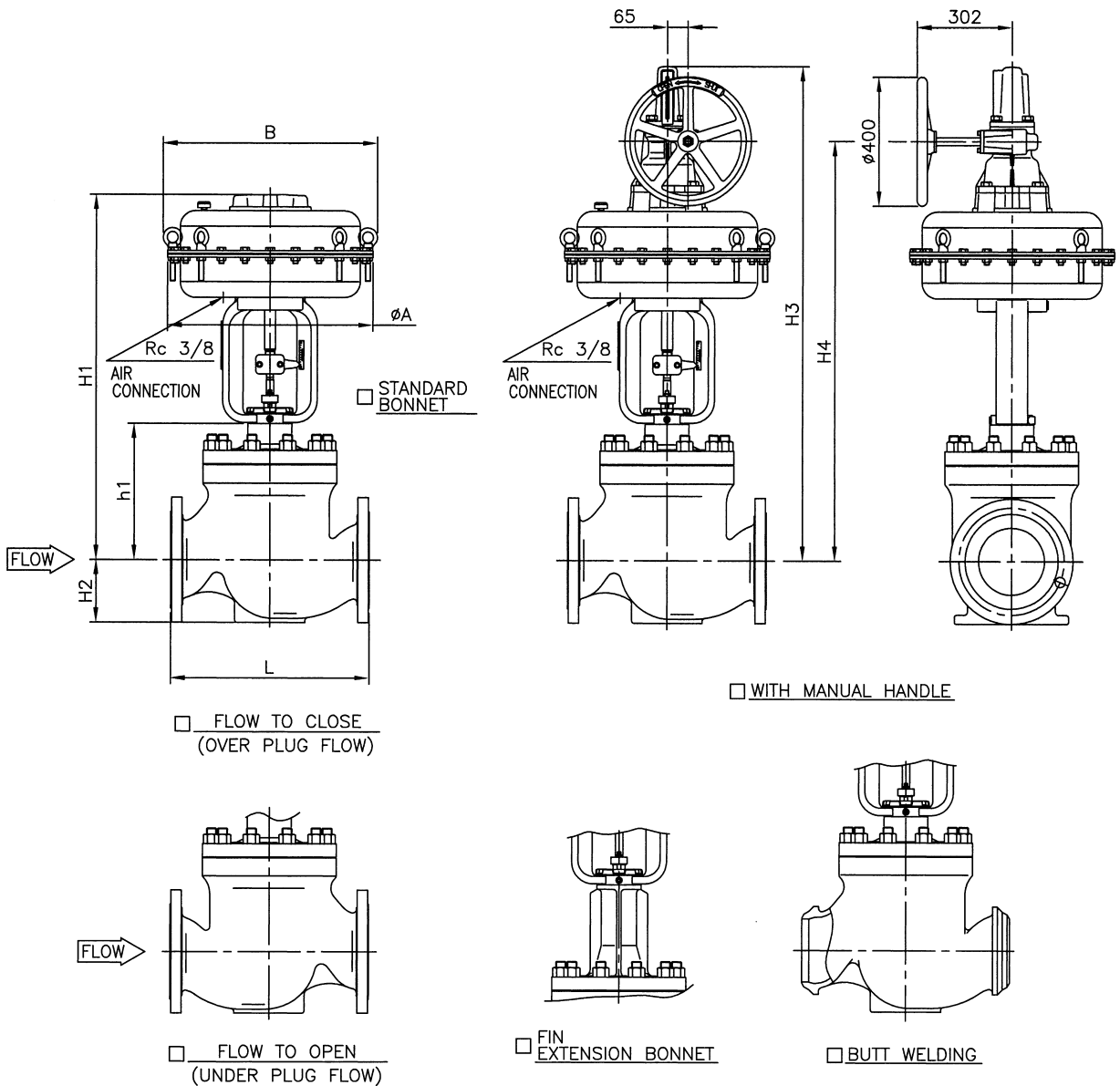

DIMENSIONS

UNIT : mm

BODY SIZE	FACE TO FACE :L								STANDARD BONNET		FIN EXTENSION BONNET		ACTUATOR				CODE NO.		
	ANSI 150#RF	ANSI 300#RF	ANSI 600#RF	ANSI 300#BW	ANSI 300#RTJ	ANSI 600#BW	ANSI 600#RTJ	H2	SIZE		WITH MANUAL HANDLE								
	JPI 150#RF	JPI 300#RF	JPI 600#RF	JPI 300#BW	JPI 300#RTJ	JPI 600#BW	JPI 600#RTJ		A	B	ST,D BONNET		FIN/EXT BONNET						
JIS 10k RF	JIS 20k RF	JIS 40k RF					h1	H1	h1	H1	H3	H4	H3	H4					
04 4" (100A)	352	368	394	368	384	394	397	113	305	1025	455	1175	650	678	1425	1190	1575	1340	526SLA
06 6" (150A)	451	473	508	473	489	508	511	144	327	1045	477	1195	650	678	1445	1215	1595	1365	526SLA
08 8"X6" (200AX150A)	543	568	610	568	584	610	613	185	365	1085	515	1235	650	678	1485	1250	1635	1400	526SLA

* FLANGE IS ACCORDING TO THE STANDARD WHICH IS DESCRIBED ON SPECIFICATION SHEET.

NOTE:

DRAWING No.

E-550G-526SLA-R-N
H

REV.

C

KOSO

GLOBE VALVE 550G DIRECT ACTION

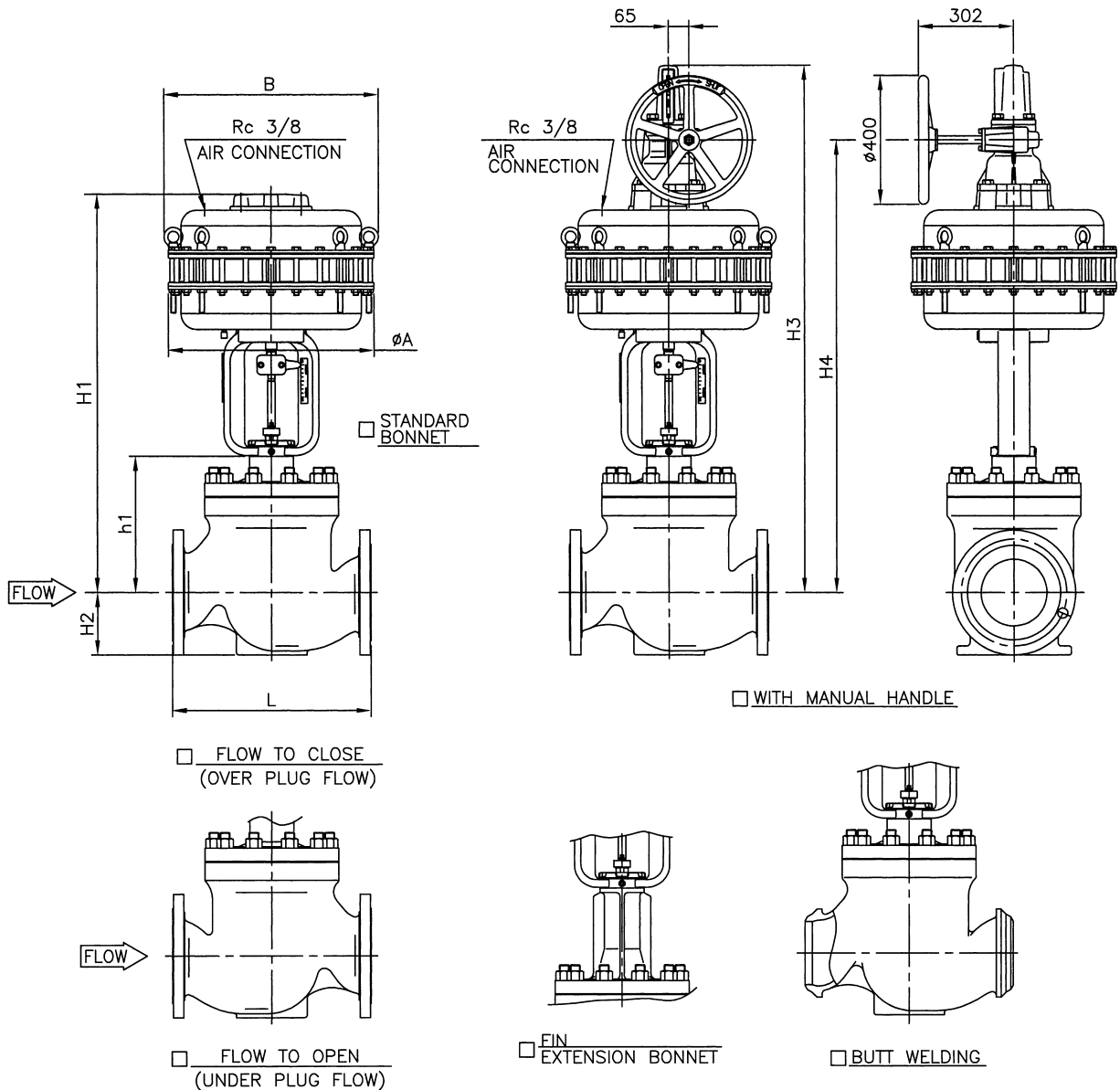

DIMENSIONS

UNIT : mm

BODY SIZE	FACE TO FACE :L								STANDARD BONNET		FIN EXTENSION BONNET		ACTUATOR				CODE NO.		
	ANSI 150#RF	ANSI 300#RF	ANSI 600#RF	ANSI 300#BW	ANSI 300#RTJ	ANSI 600#BW	ANSI 600#RTJ	H2	WITH MANUAL HANDLE		FIN/EXT BONNET		A	B	H3	H4		H3	H4
	JPI	JPI	JPI	JPI	JPI	JPI	JPI		ST,D BONNET	FIN/EXT BONNET									
08 <input type="checkbox"/> 8" (200A)	543	568	610	568	584	610	613	185	h1	H1	h1	H1	650	678	1585	1350	1735	1500	526LLA
10 <input type="checkbox"/> 10" (250A)	673	708	752	708	724	752	756	225	420	1240	570	1390	650	678	1640	1405	1790	1555	526LLA
12 <input type="checkbox"/> 12" (300A)	737	775	819	775	791	819	822	260	480	1300	630	1450	650	678	1700	1465	1850	1615	526LLA
14 <input type="checkbox"/> 14"X12" (350AX300A)	889	927	972	927	943	972	975	320	625	1445	775	1595	650	678	1845	1610	1995	1760	526LLA

* FLANGE IS ACCORDING TO THE STANDARD WHICH IS DESCRIBED ON SPECIFICATION SHEET.

NOTE:

DRAWING No.

E-550G-526LLA-D-N
H

REV.

C

KOSO

GLOBE VALVE 550G REVERSE ACTION

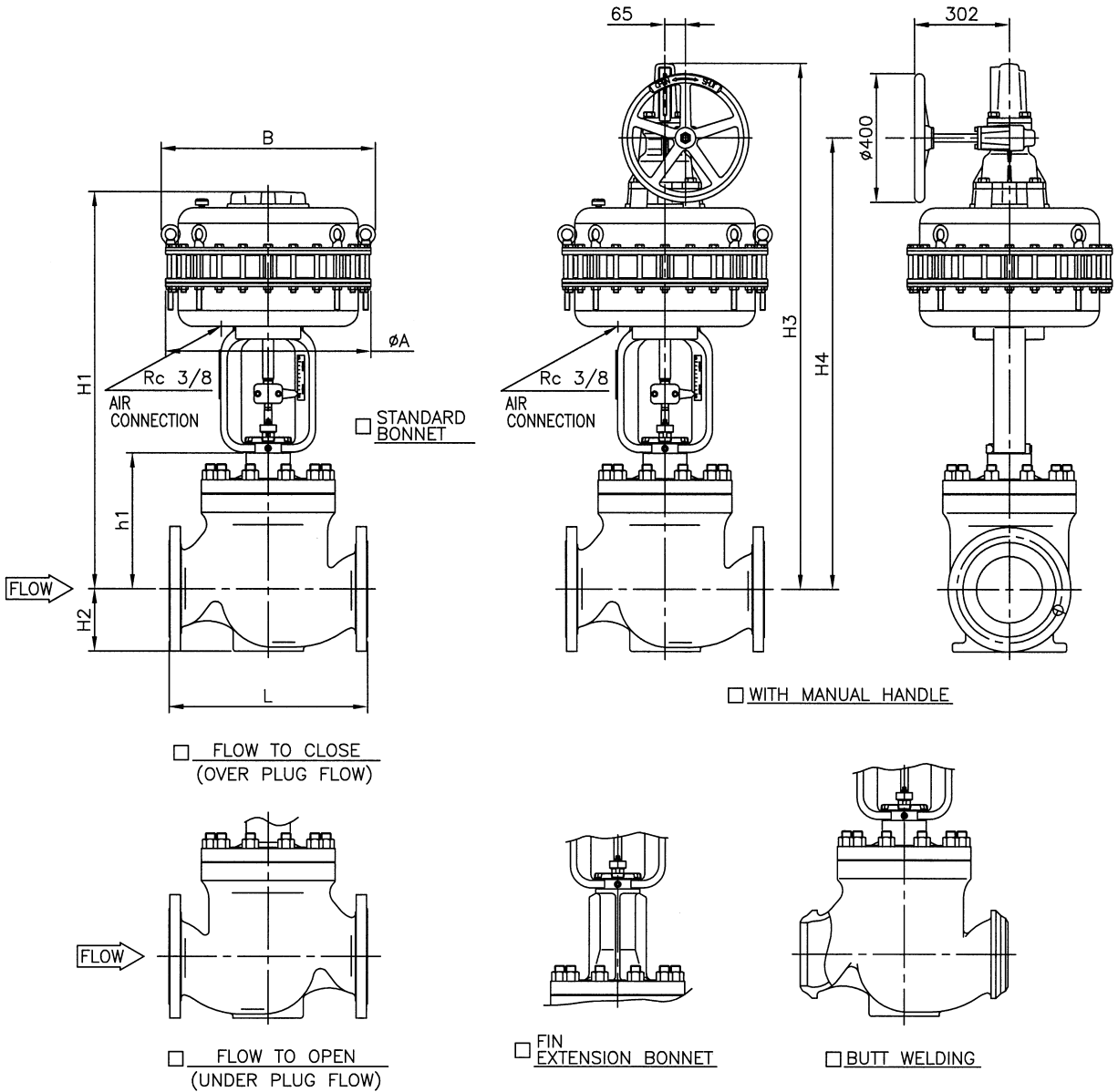

DIMENSIONS

UNIT : mm

CODE NO.	BODY SIZE	FACE TO FACE :L								STANDARD BONNET		FIN EXTENSION BONNET		ACTUATOR				CODE NO.		
		ANSI 150#RF	ANSI 300#RF	ANSI 600#RF	ANSI 300#BW	ANSI 300#RTJ	ANSI 600#BW	ANSI 600#RTJ	H2	h1	H1	h1	H1	SIZE A	B	WITH MANUAL HANDLE			CODE NO.	
		JPI	JPI	JPI	JPI	JPI	JPI	JPI	H3	H4	H3	H4								
08	8" (200A)	543	568	610	568	584	610	613	185	365	1185	515	1335	650	678	1585	1350	1735	1500	526LLA
10	10" (250A)	673	708	752	708	724	752	756	225	420	1240	570	1390	650	678	1640	1405	1790	1555	526LLA
12	12" (300A)	737	775	819	775	791	819	822	260	480	1300	630	1450	650	678	1700	1465	1850	1615	526LLA
14	14"X12" (350AX300A)	889	927	972	927	943	972	975	320	625	1445	775	1595	650	678	1845	1610	1995	1760	526LLA

* FLANGE IS ACCORDING TO THE STANDARD WHICH IS DESCRIBED ON SPECIFICATION SHEET.

NOTE:

DRAWING No.

E-550G-526LLA-R-N
H

REV.

C

KOSO

GLOBE VALVE 550G Double acting cylinder

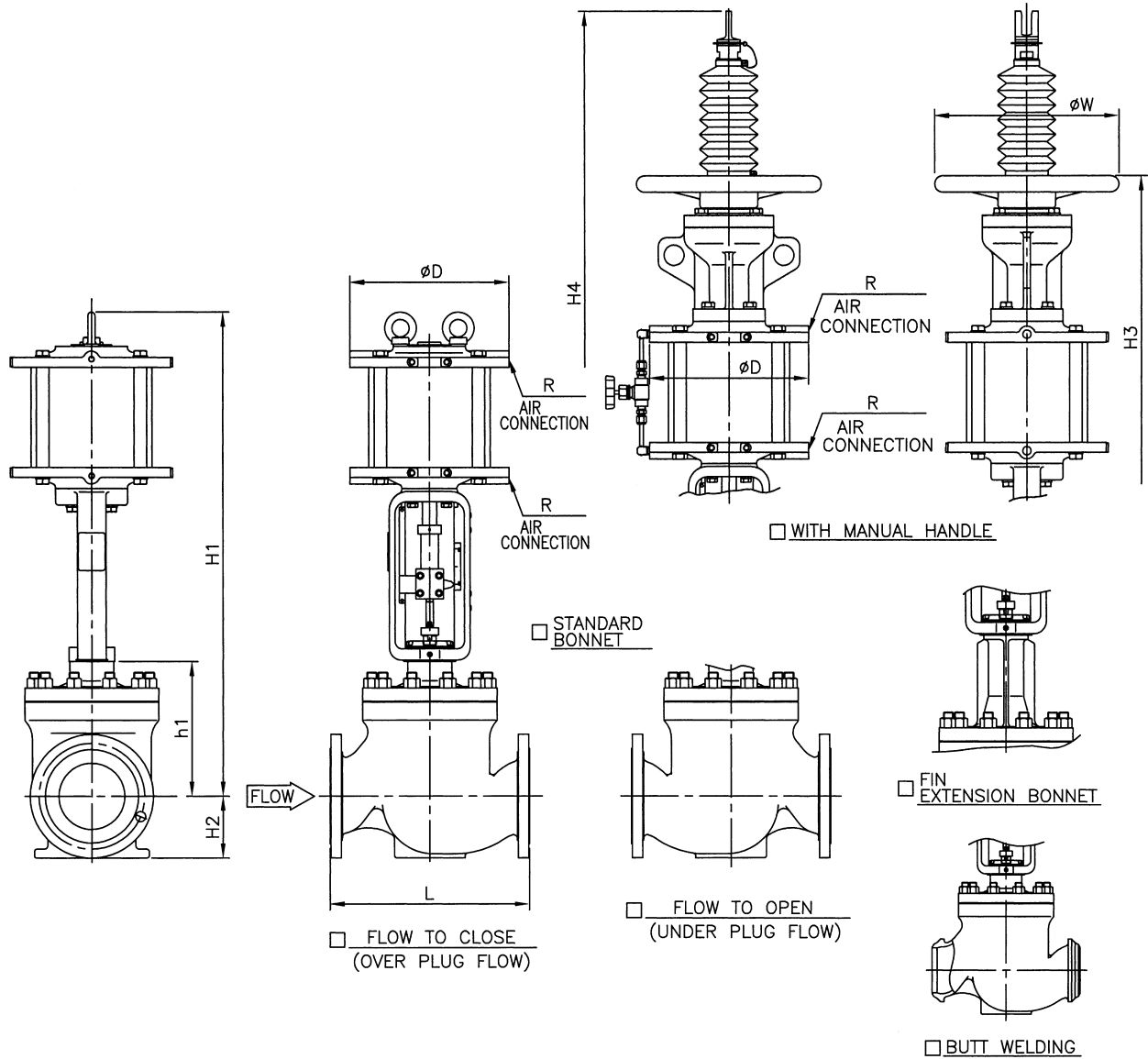

DIMENSIONS

UNIT : mm

BODY SIZE	FACE TO FACE :L								STANDARD BONNET				FIN EXTENSION BONNET				ACTUATOR										
	ANSI 150#RF	ANSI 300#RF	ANSI 600#RF	ANSI 300#BW	ANSI 300#RTJ	ANSI 600#BW	ANSI 600#RTJ	ANSI 150#RF	ANSI 300#RF	ANSI 600#RF	ANSI 300#BW	ANSI 300#RTJ	ANSI 600#BW	ANSI 600#RTJ	H2	h1	H1	H3	H4	h1	H1	H3	H4	Cylinder SIZE	D	R	WITH MANUAL HANDLE
06 (6" 150A)	451	473	508	473	489	508	511	144	327	1040	1230	1505	477	1190	1380	1655	200	272	Rc3/8	320	6320LA						
08 (8" 200A)	543	568	610	568	584	610	613	185	365	1075	1265	1540	515	1225	1415	1690	200	272	Rc3/8	320	6320LA						

* FLANGE IS ACCORDING TO THE STANDARD WHICH IS DESCRIBED ON SPECIFICATION SHEET.

NOTE:

DRAWING No.

E-550G-6320LA-W-N
T

REV.

B

KOSO

GLOBE VALVE 550G Double acting cylinder

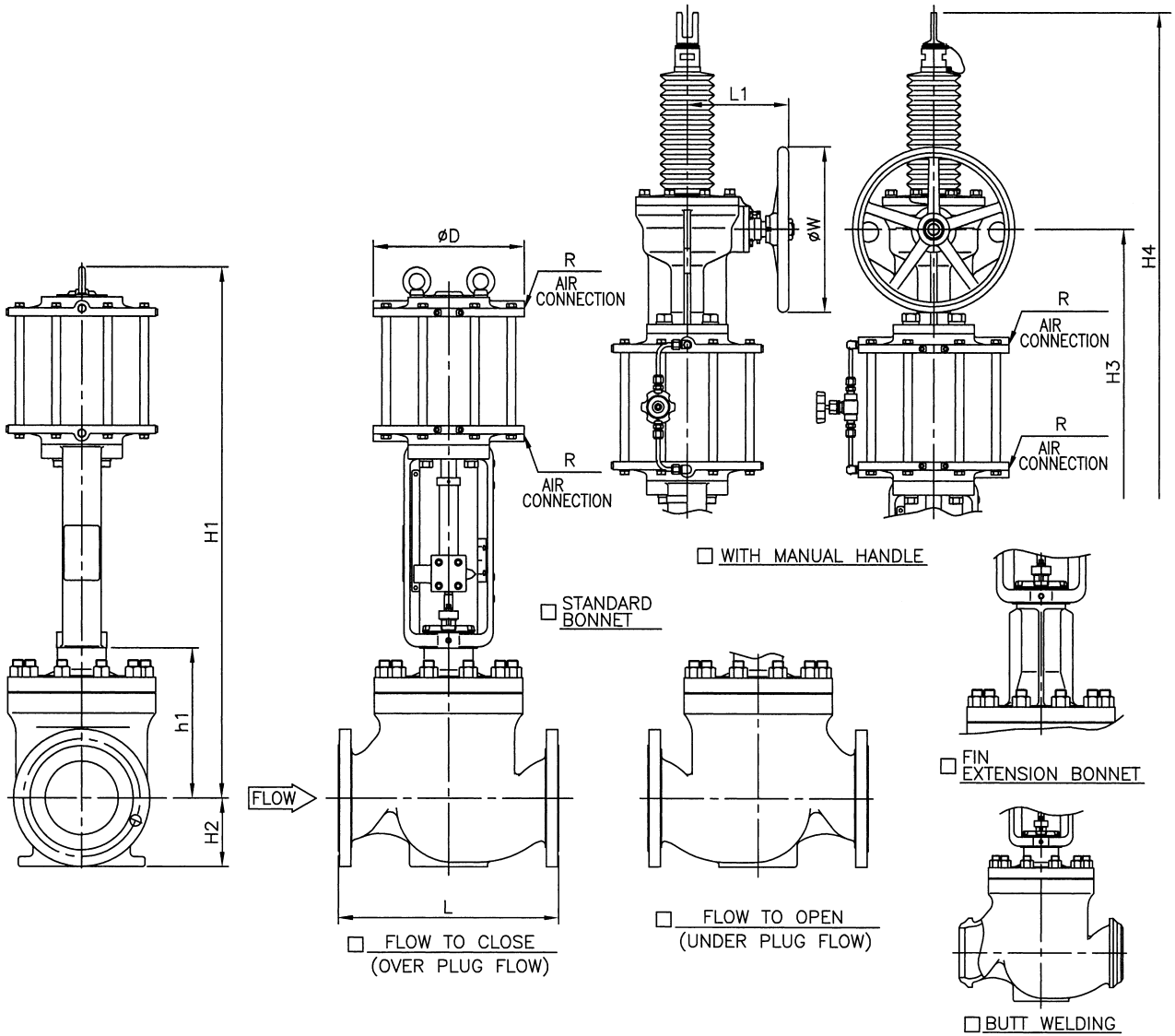

DIMENSIONS

UNIT : mm

BODY SIZE	FACE TO FACE :L							STANDARD BONNET		FIN EXTENSION BONNET				ACTUATOR								
	ANSI 150#RF JPI 150#RF JIS 10k RF	ANSI 300#RF JPI 300#RF JIS 20k RF 30k RF	ANSI 600#RF JPI 600#RF JIS 40k RF	ANSI 300#BW JPI 300#BW JIS 300#BW	ANSI 300#RTJ JPI 300#RTJ JIS 300#RTJ	ANSI 600#BW JPI 600#BW JIS 600#BW	ANSI 600#RTJ JPI 600#RTJ JIS 600#RTJ	H2	h1	H1	H3	H4	h1	H1	H3	H4	Cylinder SIZE	D	R	WITH MANUAL HANDLE L1 W	CODE NO.	
06 (6" / 150A)	451	473	508	473	489	508	511	144	327	1100	1255	1715	477	1250	1405	1865	300	382	Rc1/2	260	400	6330LA
08 (8" / 200A)	543	568	610	568	584	610	613	185	365	1135	1290	1750	515	1285	1440	1900	300	382	Rc1/2	260	400	6330LA
										1315	1525	2080		450	555	Rc1/2	330	500	6345LA			
10 (10" / 250A)	673	708	752	708	724	752	756	225	420	1190	1345	1805	570	1340	1495	1955	300	382	Rc1/2	260	400	6330LA
										1370	1580	2135		450	555	Rc1/2	330	500	6345LA			
12 (12" / 300A)	737	775	819	775	791	819	822	260	480	1250	1405	1865	630	1400	1555	2015	300	382	Rc1/2	260	400	6330LA
										1430	1640	2195		450	555	Rc1/2	330	500	6345LA			
										1565	1770	2435		600	730	Rc3/4	445	630	6360LA			
14 (14" / 350A)	889	927	972	927	943	972	975	320	625	1775	1985	2640	775	1925	2135	2790	450	555	Rc1/2	330	500	6345LA
										1910	2115	2880		600	730	Rc3/4	445	630	6360LA			
16 (16" / 400A)	1016	1057	1108	1057	1073	1108	1111	370	720	1870	2080	2735	870	2020	2230	2885	450	555	Rc1/2	330	500	6345LA
										2005	2210	2975		600	730	Rc3/4	445	630	6360LA			
18 (18" / 450A)	1140	1181	1239	1181	1197	1239	1242	420	815	1965	2175	2830	965	2115	2325	2980	450	555	Rc1/2	330	500	6345LA

* FLANGE IS ACCORDING TO THE STANDARD WHICH IS DESCRIBED ON SPECIFICATION SHEET.

NOTE:

DRAWING No.

E-550G-6300LA-W-N
H

REV.

C

KOSO

GLOBE VALVE 550G Motorized Actuator 3500LC 3600LA

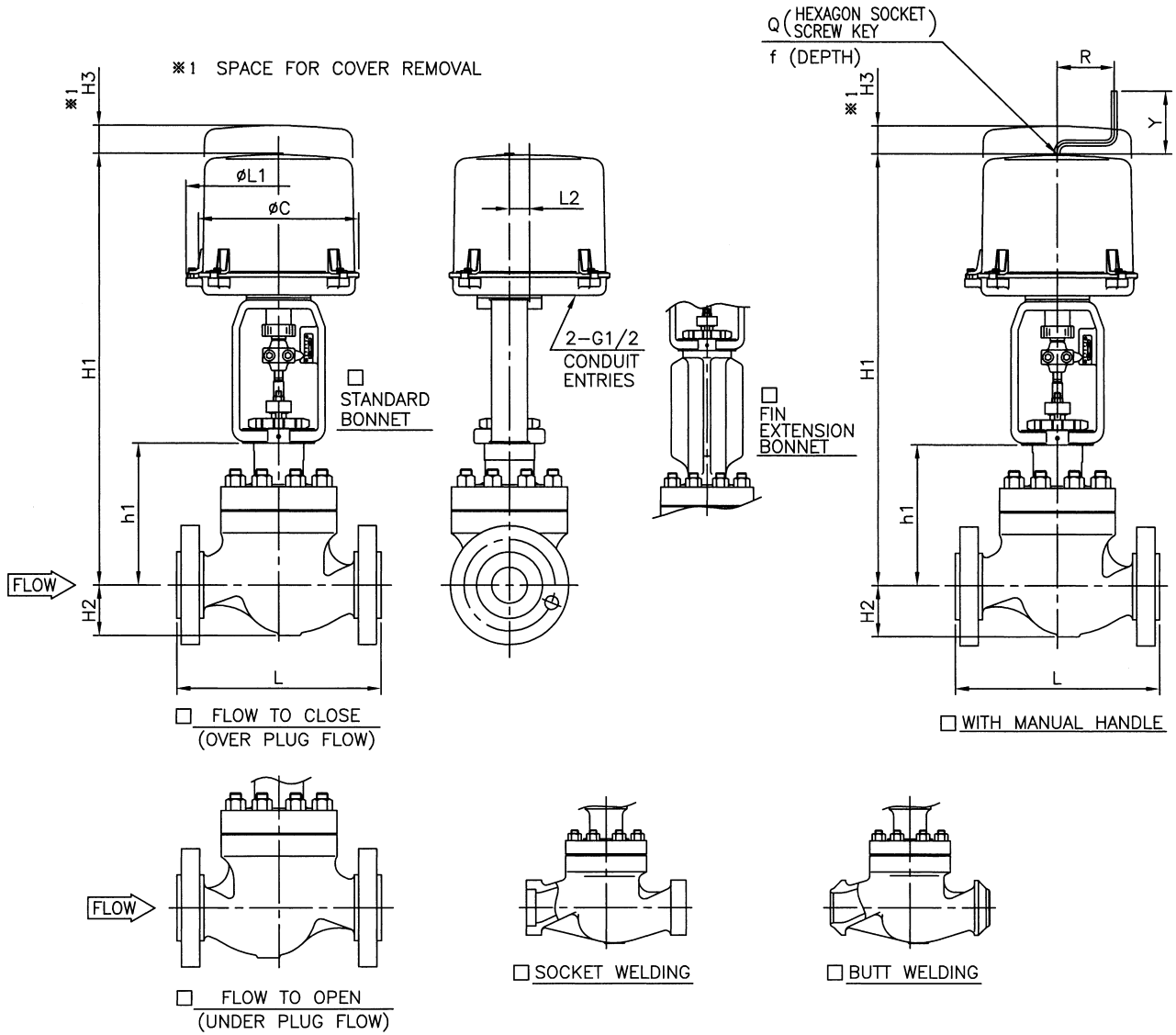

DIMENSIONS

UNIT : mm

BODY SIZE	FACE TO FACE :L								STANDARD BONNET		FIN EXTENSION BONNET		ACTUATOR									
	ANSI 150#RF	ANSI 300#RF	ANSI 600#RF	ANSI 300#SW	ANSI 300#RTJ	ANSI 600#SW	ANSI 600#RTJ	H2	h1	H1	h1	H1	H3	øL1	L2	øC	WITH MANUAL HANDLE				SIZE CODE NO.	
	JPI 150#RF	JPI 300#RF	JPI 600#RF	JPI 300#BW	JPI 300#RTJ	JPI 600#BW	JPI 600#RTJ										R	Y	Q-f			
01 1" (25A)	184	197	210	210	210	210	210	47	157	560	257	660	205	260	28	225	80	87	6-12	35A2LC	36A2LA	
93 1 1/2" (40A)	222	235	251	251	248	251	251	60	175	580	730	790	260	290	45	255	160	90	8-15	35B1LC	36B1LA	
										755	905	855	260	290	45	255	160	90	8-15	35B2LC	36B2LA	
02 2" (50A)	254	267	286	286	283	286	289	70	196	600	730	780	260	290	45	255	160	90	8-15	35A2LC	36A2LA	
										780	880	930	260	290	45	255	160	90	8-15	35B1LC	36B1LA	
03 3" (80A)	298	317	337	317	333	337	340	98	201	605	735	785	260	290	45	255	160	90	8-15	35A2LC	36A2LA	
										785	885	935	260	290	45	255	160	90	8-15	35B1LC	36B1LA	
04 4" (100A)	352	368	394	368	384	394	397	113	275	855	425	1005	260	290	45	255	160	90	8-15	35B2LC	36B2LA	
										855	425	1005	260	290	45	255	160	90	8-15	35B2LC	36B2LA	
06 6" (150A)	451	473	508	473	489	508	511	144	305	885	455	1035	260	290	45	255	160	90	8-15	35B2LC	36B2LA	

* FLANGE IS ACCORDING TO THE STANDARD WHICH IS DESCRIBED ON SPECIFICATION SHEET.

NOTE:

DRAWING No.

E-550G-3500LC-B-N
3600LA-T

REV.

C

KOSO

GLOBE VALVE 550G Motorized Actuator 36C0LA

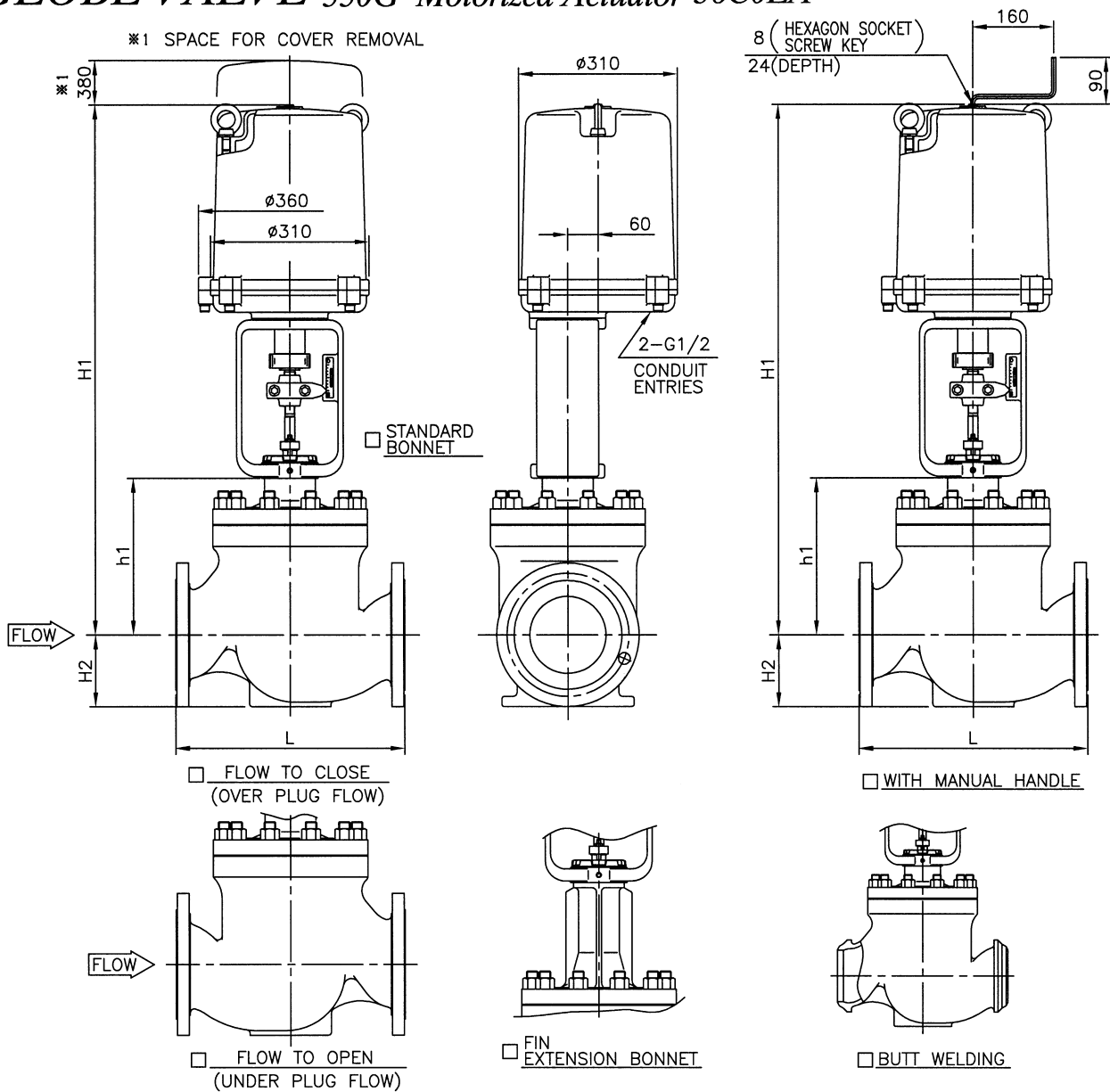

DIMENSIONS

UNIT : mm

BODY SIZE	FACE TO FACE :L							H2	STANDARD BONNET		FIN EXTENSION BONNET		ACTUATOR SIZE CODE NO.
	ANSI 150#RF JPI 150#RF JIS 10k RF	ANSI 300#RF JPI 300#RF JIS 20k RF 30k RF	ANSI 600#RF JPI 600#RF JIS 40k RF	ANSI 300#BW JPI 300#BW	ANSI 300#RTJ JPI 300#RTJ	ANSI 600#BW JPI 600#BW	ANSI 600#RTJ JPI 600#RTJ		h1	H1	h1	H1	
03 3" (80A)	298	317	337	317	333	337	340	98	201	930	351	1080	36C1LA
04 4" (100A)	352	368	394	368	384	394	397	113	275	1000	425	1150	36C1LA
									305	1090	455	1240	36C2LA
06 6" (150A)	451	473	508	473	489	508	511	144	305	1030	455	1180	36C1LA
									327	1115	477	1265	36C2LA
08 8" (200A)	543	568	610	568	584	610	613	185	365	1150	515	1300	36C2LA
10 10" (250A)	673	708	752	708	724	752	756	225	420	1205	570	1355	36C2LA
12 12" (300A)	737	775	819	775	791	819	822	260	480	1265	630	1415	36C2LA
14 14"X12" (350AX300A)	889	927	972	927	943	972	975	320	625	1410	775	1560	36C2LA

* FLANGE IS ACCORDING TO THE STANDARD WHICH IS DESCRIBED ON SPECIFICATION SHEET.

NOTE:

DRAWING No.

E-550G-36C0LA-B-N

REV.

C

KOSO

図6 5200LA駆動部取付姿勢

Fig. 6 ACTUATOR MOUNTING FORMS FOR 5200LA

図6-1 駆動部サイズ：218～450

Fig. 6-1 ACTUATOR SIZE : 218 ~ 450



図6-2 駆動部サイズ：650

Fig. 6-2 ACTUATOR SIZE : 650

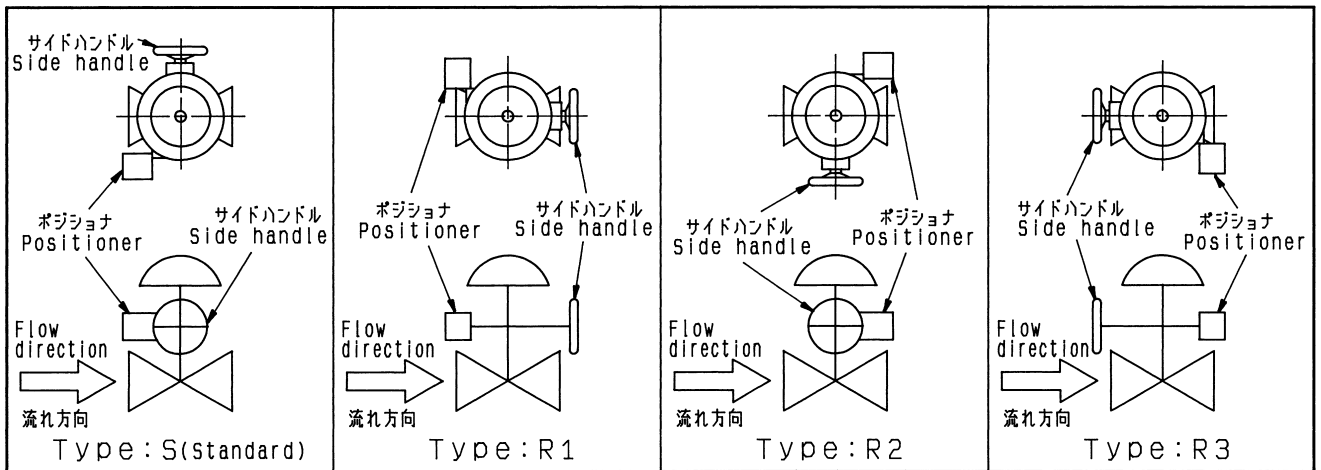
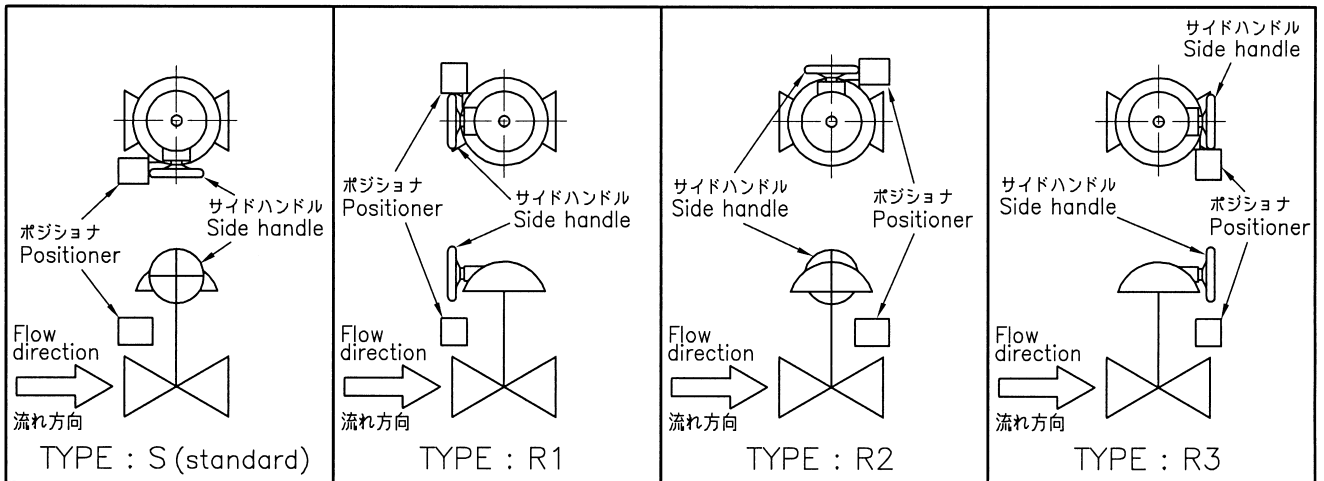

注：標準取付姿勢Type:S以外の場合は、取付姿勢を御指定下さい。

Note : Type S is automatically applied, unless otherwise specified.

図7 3500LC・3600LA・3400LA駆動部取付姿勢

Fig. 7 ACTUATOR MOUNTING FORMS FOR 3500LC・3600LA・3400LA

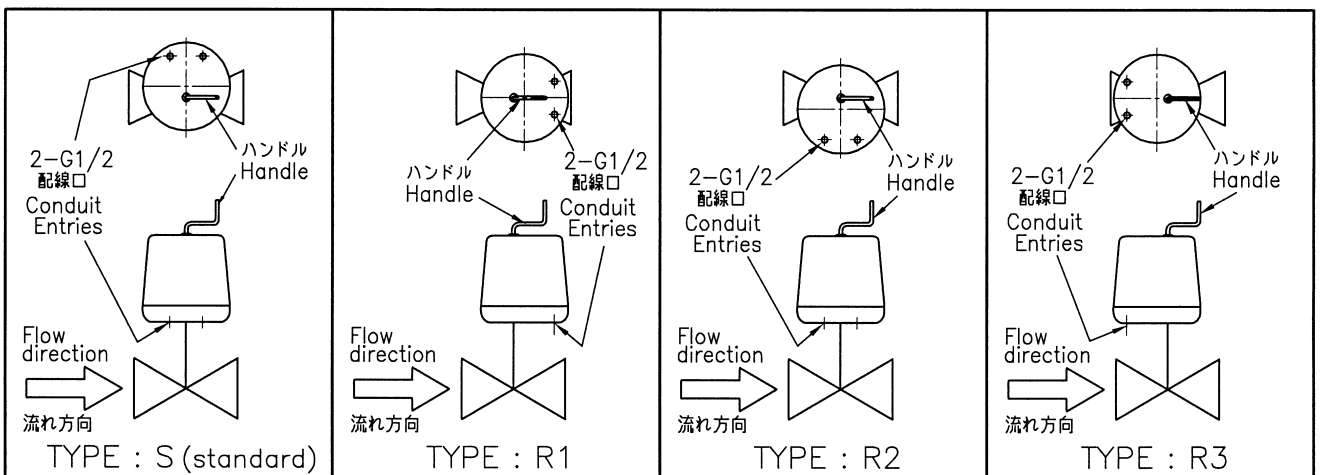

注：標準取付姿勢Type:S以外の場合は、取付姿勢を御指定下さい。

Note : Type S is automatically applied, unless otherwise specified.

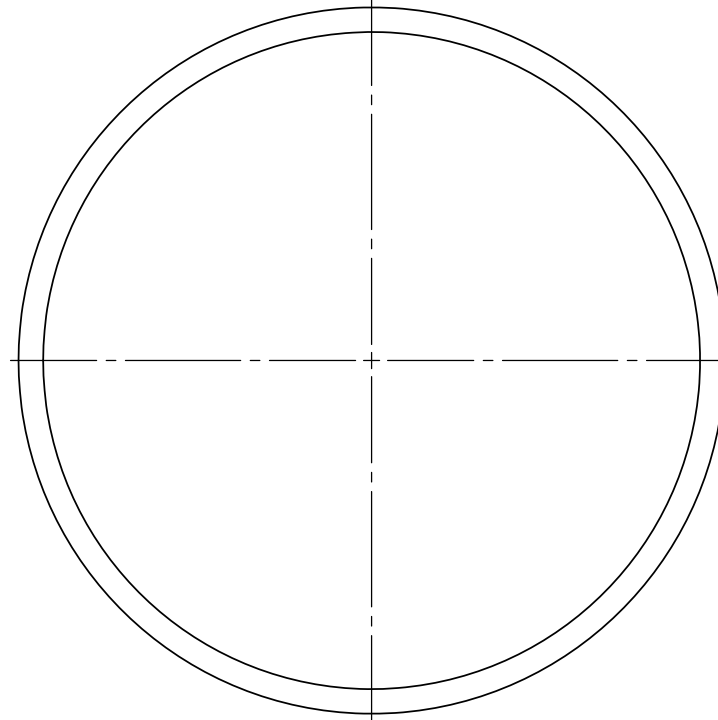
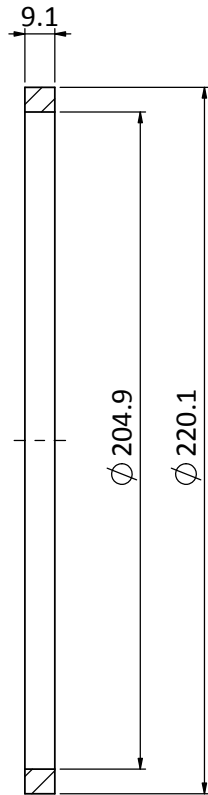

	MBOM Part No.
KCK	M00002751
NK	
KEC	

Specification 501G, -, -, 8", -, -, Graphite seal, 47828.8mm ³						Surface roughness			Third angle	Scale N/S	Material Graphite	Component name Balance seal		
△5						Machining instruction General tolerance without tolerance indication(mm) Surface roughness : JIS B 0601 Ra Welding symbol : JIS Z 3021 Tolerance : JIS B 0021	30 and less : ±0.2 Over 30 to under 120 : ±0.3 120 and over to under 315 : ±0.5 Chamfering : C0.1 Fillet without indication : R0.3	Finish		Issued	CH.Y	2017-10-24	NK Drawing No. VCK3038A-R0	
△4					Checked					JY.L	2017-10-24	KCK Drawing No. 00000570		
△3					Approved					JH.K	2017-10-24			
△2														
△1														
Revisions														

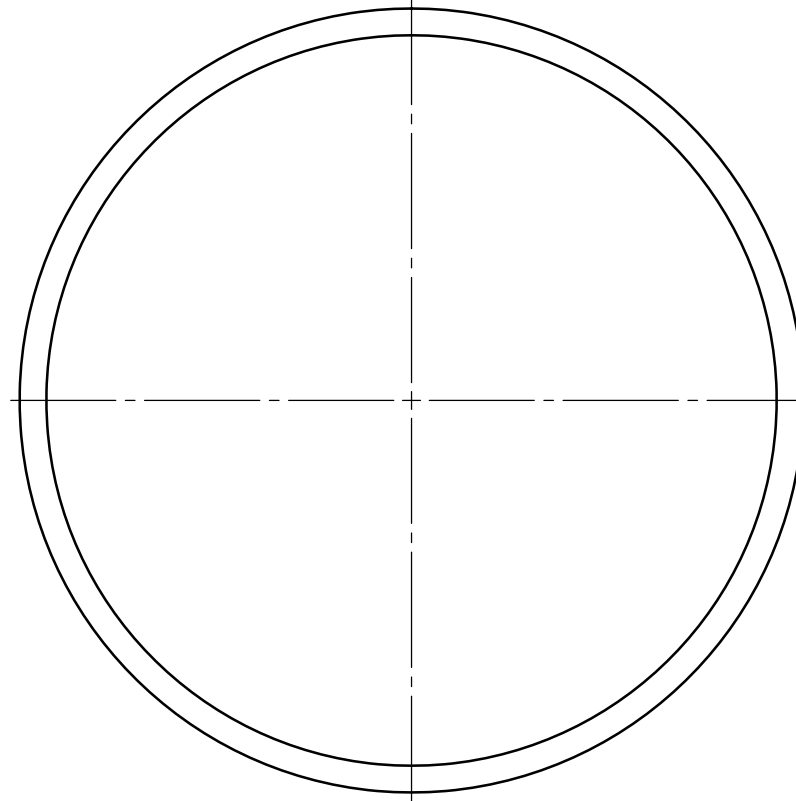
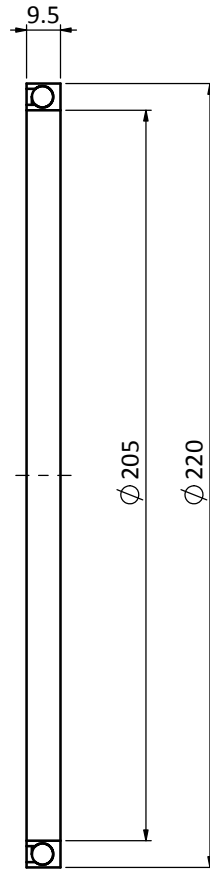

	MBOM Part No.
KCK	M00002730
NK	
KEC	

Specification 501G, -, -, 8", -, -, Lip seal, 42123.0mm ³													
△5						Surface roughness	Third angle	Scale N/S	Material	Component name			
△4									RTFE+316SS	Balance seal			
△3						Machining instruction	General tolerance without tolerance indication(mm)			Issued	CH.Y	2017-10-24	NK Drawing No.
△2						Surface roughness : JIS B 0601 Ra Welding symbol : JIS Z 3021 Tolerance : JIS B 0021	30 and less : ±0.2 Over 30 to under 120 : ±0.3 120 and over to under 315 : ±0.5 Chamfering : C0.1 Fillet without indication : R0.3	Finish	Checked	JY.L	2017-10-24	AR103-P205-PU	
△1									Approved	JH.K	2017-10-24	KCK Drawing No.	
Revisions												00001237	(1 / 1)

表4 標準駆動部との組合せ概算製品質量(単位: kg)

Table 4 NET WEIGHT OF STANDARD VALVE AND ACTUATOR COMBINED (UNIT : kg)

弁本体部及び駆動部は標準品の質量で、付属品並びに手動操作機構などの質量を含んでいません。

Only standard types are represented. Weights of accessories, a handwheel and the like are not included.

弁サイズ Body size	弁本体定格 Body rating class		ダイヤフラム式駆動部サイズ Diaphragm actuator size							複動形シリンダ式駆動部サイズ Double acting Cylinder actuator size					電子式駆動部サイズ Electronic Actuator size		
			5200LA							6300LA					35A2LC	35B1LC	36C1LA
			ANSI	JIS	218	270	350	450S	450L	650S	650L	150	200	300	450	600	36A2LA
inch(mm)																	
1 (25)	150	10K	18	24	40										16	22	
	300	20, 30K	19	25	41										17	23	
	600	40K	20	26	42										18	24	
1½ (40)	150	10K	29	36	52										28	34	
	300	20, 30K	34	41	57										33	39	
	600	40K	39	46	62										38	44	
2 (50)	150	10K		41	57	92									33	39	
	300	20, 30K		46	62	97									38	44	
	600	40K		51	67	102									43	49	
3 (80)	150	10K		56	72	107									48	54	90
	300	20, 30K		66	82	117									58	64	100
	600	40K		91	107	142									83	89	125
4 (100)	150	10K				115	137	242								64	100
	300	20, 30K				130	152	257								79	115
	600	40K				175	197	302								124	160
6 (150)	150	10K					200	322		160	185	220				144	180
	300	20, 30K					230	352		190	215	250				174	210
	600	40K					280	402		250	275	310				224	260
8 (200)	150	10K					280	402			285	320	426				260
	300	20, 30K					330	452			295	330	436				310
	600	40K					450	572			405	440	546				430
10 (250)	150	10K					470	603				460	566				428
	300	20, 30K					550	683				540	646				508
	600	40K					790	923				780	886				748
12 (300)	150	10K						773				630	736	838			598
	300	20, 30K						853				710	816	918			678
	600	40K						1143				1000	1106	1208			968
14 (350)	150	10K						1045					1070	1190			
	300	20, 30K						1205					1230	1350			
	600	40K						1705					1730	1850			
16 (400)	150	10K											1530	1650			
	300	20, 30K											1930	2050			
	600	40K											2730	2850			
18 (450)	150	10K											2230	2350			
	300	20, 30K											2930	3050			
	600	40K											4230	4350			

KOSO 日本工装株式会社

NIHON KOSO CO., LTD.

本社 〒103-0027 東京都中央区日本橋1-16-7(工装日本橋ビル)
TEL. 03(5202)4300(代表) FAX. 03(5202)4301
Head Office 1-16-7, Nihombashi, Chuo-ku, Tokyo, 103-0027, Japan
TEL. 81-3-5202-4300 FAX. 81-3-5202-4301

東日本営業部 〒103-0027 東京都中央区日本橋1-16-7(工装日本橋ビル)
TEL. 03(5202)4300(代表) FAX. 03(5202)4301
西日本営業部 〒564-0062 大阪府吹田市垂水町3-31-29
TEL. 06(6378)7117(代表) FAX. 06(6378)7050
CSC北海道 〒053-0047 北海道苫小牧市泉町1-1-6
TEL. 0144(31)4400(代表) FAX. 0144(31)4401
CSC仙台 〒989-2322 宮城県亶理郡亶理町逢隈蔵字卯49-1
TEL. 0223(33)1891(代表) FAX. 0223(33)1892
CSC福島 〒962-0312 福島県須賀川市大久保字川虫内129
TEL. 0248(65)3128(代表) FAX. 0248(65)3224
CSC新潟 〒950-0813 新潟県新潟市東区大形本町5-12-36
TEL. 025(275)8461(代表) FAX. 025(275)8462
CSC鹿島 〒314-0115 茨城県神栖市知手3612-1
TEL. 0299(96)6891(代表) FAX. 0299(96)6892
CSC関東 〒290-0057 千葉県市原市五井金杉1-42
TEL. 0436(22)0604(代表) FAX. 0436(21)1311
CSC戸田 〒335-0035 埼玉県戸田市笹目南町12-13
TEL. 048(421)5111(代表) FAX. 048(421)5115
CSC富士 〒416-0909 静岡県富士市松岡14-1
TEL. 0545(66)3191(代表) FAX. 0545(66)3192
CSC名古屋 〒486-0935 愛知県春日井市森山田町62
TEL. 0568(34)1421(代表) FAX. 0568(34)1431
CSC大阪 〒564-0062 大阪府吹田市垂水町3-31-29
TEL. 06(6378)7117(代表) FAX. 06(6378)7050
CSC広島 〒731-5127 広島県広島市佐伯区五日市1-8-25
TEL. 082(943)7750(代表) FAX. 082(922)9033
CSC岡山 〒712-8061 岡山県倉敷市神田3-8-29
TEL. 086(444)1802(代表) FAX. 086(444)1812
CSC九州 〒802-0802 福岡県北九州市小倉南区城野4-5-55
TEL. 093(922)3431(代表) FAX. 093(951)1435
CSC大分 〒870-0901 大分県大分市西新地1-8-17
TEL. 097(551)4816(代表) FAX. 097(551)4827

WORLD-WIDE NETWORK(Sales, Manufacturing, Services)

Nihon Koso Co., Ltd., Tokyo Japan	Tel. (81)3-5202-4300	Fax. (81)3-5202-4301
Paris Office	Tel. (33)1-73-75-23-1	Fax. (83)1-73-75-23-1
Moscow Office	Tel. (7)495-775-8531	Fax. (7)495-787-2785
Dubai branch	Tel. (971)4-881-3090	Fax. (971)4-881-5090
Beijin Office	Tel. (86)10-5877-2863	Fax. (86)10-5877-2867
Koso M-Mac International, Inc., CA, U.S.A.	Tel. (1)661-942-4499	Fax. (1)661-942-0999
Koso America, Inc., Boston, U.S.A.	Tel. (1)508-584-1199	Fax. (1)508-584-2525
Pacific Seismic Products, Inc., CA, U.S.A.	Tel. (1)661-942-4499	Fax. (1)661-942-0999
Koso Kent Introl Ltd., U.K.	Tel. (44)1484-710311	Fax. (44)1484-407407
Koso Control Engineering (Wuxi) Co., Ltd., China	Tel. (86)510-85129961	Fax. (86)510-85127827
Wuxi Koso Fluid Control Co., Ltd., China	Tel. (86)510-85101567	Fax. (86)510-85105339
Wuxi Koso Valve Casting Co., Ltd., China	Tel. (86)510-85117433	Fax. (86)510-85117433
Hangzhou Hangyang KOSO P & V Co., Ltd.	Tel. (86)571-85869508	Fax. (86)571-85343203
Koso-AACI (Anshan) Co., Ltd., China	Tel. (86)412-8812686	Fax. (86)412-8814582
Korea Koso Co., Ltd., Seoul, Korea	Tel. (85)2-539-9011	Fax. (82)2-566-5119
Korea Koso Engineering Co., Ltd., Seoul, Korea	Tel. (85)2-539-9018	Fax. (82)2-566-5119
Koso Controls Asia Pte. Ltd., Singapore	Tel. (65)67472722	Fax. (65)67467677
Kent Introl Private Ltd., India	Tel. (91)253-2383111	Fax. (91)253-2384413
Koso Fluid Controls Private Ltd., India	Tel. (91)491-2566047	Fax. (91)491-2567142

※この資料の記載内容は、お断りなく変更することがありますのでご了承下さい。
Subject to change without notice.